

Polynesian Journal of Mathematics

Volume 2, Issue 6

Functorial semantics for relational theories

Filippo Bonchi

Dusko Pavlovic

Paweł Sobociński

Received 23 Oct 2024

Revised 5 Oct 2025

Accepted 9 Oct 2025

Published 20 Oct 2025

Communicated by Gaetan Bisson

DOI: 10.69763/polyjmath.2.6

Functorial semantics for relational theories

Filippo Bonchi¹ Dusko Pavlovic² Paweł Sobociński³

¹Dipartimento di Informatica, Università degli Studi di Pisa, Italy

²Adaptive Security and Economics Lab, University of Hawaii at Manoa, United States of America

³Laboratory for Compositional Systems and Methods, Tallinn University of Technology, Estonia

Abstract

We introduce the concept of *Frobenius theory* as a generalisation of Lawvere’s functorial semantics approach to categorical universal algebra. Whereas the universe for models of Lawvere theories is the category of sets and functions, or more generally cartesian categories, Frobenius theories take their models in the category of sets and relations, or more generally in cartesian bicategories.

1 Introduction and roadmap

There has been a recent explosion of interest in algebraic structures borne by objects of symmetric monoidal categories [35], with applications in quantum foundations [1, 19, 21], concurrency theory [7], control theory and engineering [2, 14, 3], linguistics and formal language theory [46, 49, 48], database theory [9] and probability theory [30] amongst others. In several cases these “resource-sensitive” algebraic theories are presented using generators and equations. Moreover, many contain Frobenius algebra [18] as a sub-theory, which yields a self-dual compact closed structure and gives the theories a relational flavour, e.g. a dagger operation, which one can often think semantically as giving the *opposite relation*. In this paper we propose a *categorical universal algebra* for such monoidal theories, generalising functorial semantics, the classical approach due to Lawvere. A notion of model clarifies the conceptual landscape, and is a useful tool for the study of the algebraic theories themselves. For example: how can one show that a particular equation does *not* hold in a theory? Reasoning

Bonchi was supported by the Advanced Research and Invention Agency (ARIA) Safeguarded AI Programme; the National Centre on HPC, Big Data and Quantum Computing – SPOKE 10 (Quantum Computing); the EU Next-GenerationEU – National Recovery and Resilience Plan (NRRP) – Mission 4, Component 2, Investment № 1.4 – CUP № I53C22000690001; the EPSRC grant № EP/V002376/1; and by the *Ministero dell’Università e della Ricerca* of Italy grant PRIN 2022 PNRR № P2022HXNSC – RAP (Resource Awareness in Programming).

Sobociński was supported by the Advanced Research and Invention Agency (ARIA) Safeguarded AI Programme; by the Estonian Research Council via grants PRG1215 and TEM-TA5; the Estonian Center of Excellence in Artificial Intelligence (EXAI); and by the European Union under Grant Agreement № 101087529.

directly with an equational theory can be difficult, since showing that an equation is *not* derivable from a set of axioms using equational reasoning is often difficult. Instead, one obvious way is to find a model where the equation does not hold.

1.1 Functorial semantics

Lawvere categories [39] (also known as finite product theories) are a standard setting for classical universal algebra. Syntactically speaking, terms are trees where some leaves are labelled with variables, and these can be copied and discarded arbitrarily. Categorically, this means a finite product structure, and (classical) models are *product preserving functors*. In particular, to give the classical notion of model as a set, together with appropriate n -ary functions, satisfying the requisite equations, is to give a product preserving functor from the corresponding Lawvere category to the category of sets and functions $\mathcal{L} \rightarrow \mathbf{Set}$. This methodology is commonly referred to as *functorial semantics*.

For example, commutative monoids are exactly the product preserving functors from the Lawvere category of commutative monoids, abelian groups the product preserving functors from the Lawvere category of abelian groups, etc. Moreover, the usual notion of homomorphism between models is given by natural transformations between models-as-functors.

Specification	algebraic theory
Syntax	trees
Category	Lawvere category (finite product category)
Models	product preserving functors
Homomorphisms	natural transformations

In applications, classical algebraic theories are often not the right fit. Sometimes this is because an underlying data type is not classical, e.g. qubits, that cannot be copied. Other times it's because one needs to be explicit about the actual copying and discarding being carried out *as (co)algebraic operations*, instead of relying on an implicit cartesian structure. That is, we require a *resource sensitive syntax*. In practice, this means replacing algebraic theories with symmetric monoidal theories (SMTs), trees with string diagrams, cartesian product with symmetric monoidal product (Lawvere categories with props), and product preserving functors with monoidal functors. This suggests an updated table:

Specification	symmetric monoidal theory (SMT)
Syntax	string diagrams
Category	prop
Models	symmetric monoidal functors
Homomorphisms	monoidal natural transformations

Props are symmetric strict monoidal categories with objects the natural numbers, such that $m \oplus n = m + n$. Of course, any Lawvere category is an example of a prop, since

the cartesian structure induces a canonical symmetry. Arrows of (freely generated) props seem, therefore, to offer an attractive solution to the quest for resource sensitive syntax. Given that the underlying monoidal product is not assumed to be cartesian, props give the possibility of considering bona fide operations with co-arities other than one, e.g. the structure (comultiplication and counit) of a comonoid. In fact, comonoids are the bridge [28] between the classical and the resource-sensitive.

Roughly speaking, given an algebraic theory, we can regard it as a symmetric monoidal theory by “encoding” the cartesian structure with comonoids. More precisely, one introduces a commutative comonoid (copying) and equations making all other operations comonoid homomorphisms:

$$\begin{array}{c}
 \begin{array}{c} \text{---} \\ \text{---} \end{array} \text{---} \boxed{f} \bullet \begin{array}{c} \text{---} \\ \text{---} \end{array} = \begin{array}{c} \text{---} \\ \text{---} \end{array} \bullet \begin{array}{c} \boxed{f} \\ \boxed{f} \end{array} \begin{array}{c} \text{---} \\ \text{---} \end{array} \quad \begin{array}{c} \text{---} \\ \text{---} \end{array} \boxed{f} \bullet = \text{---} \bullet \begin{array}{c} \text{---} \\ \text{---} \end{array} \quad (1)
 \end{array}$$

This leads one to observe that, as props, the following are actually isomorphic:

$$\begin{array}{c}
 \text{Lawvere category } \mathcal{L}_{\text{CM}} \text{ of commutative monoids CM} \\
 \cong \\
 \text{prop } \mathcal{P}_{\text{B}} \text{ of (co/commutative) bialgebras B}
 \end{array}$$

Thus, in effect, bialgebras are what one gets by considering classical commutative monoids and taking resource sensitivity seriously. Similarly, Hopf algebras can be seen as abelian groups in a “resource sensitive” universe:

$$\begin{array}{c}
 \text{Lawvere category } \mathcal{L}_{\text{AG}} \text{ of abelian groups AG} \\
 \cong \\
 \text{prop } \mathcal{P}_{\text{H}} \text{ of (co/commutative) Hopf algebras}
 \end{array}$$

The structure of props suggests that, for models, we ought to look at symmetric monoidal functors. Indeed, considering the monoidal category of sets and functions **Set** (with cartesian product as monoidal product) as codomain, the symmetric monoidal functors from the prop of commutative monoids are in bijective correspondence with ordinary commutative monoids. Here it is the products of **Set** that ensure that, although the theory is non-cartesian, the models are classic. Similarly, commutative monoids are captured by symmetric monoidal functors $\mathcal{P}_{\text{B}} \rightarrow \mathbf{Set}$; it is not difficult to show that the only comonoid action on a set is given by the diagonal, so the “copying” comonoid structure is uniquely determined in any **Set**-model of \mathcal{P}_{B} .

1.2 Relations as a universe for models

Our goal is to study algebras of relations, e.g. relational algebra, allegories, Kleene algebra, automata, labelled transition systems, etc. We are therefore interested in developing a theory of functorial semantics that takes its models in the monoidal category \mathbf{Rel}_\times : objects are sets, arrows are relations, and the subscript indicates that we take cartesian product as monoidal product.

Here mere props and monoidal functors are not enough to characterise commutative monoids. Considering the prop of commutative monoids, monoidal functors to \mathbf{Rel}_\times are not guaranteed to give a functional monoid action: e.g., one could map the monoid action to the opposite of the diagonal relation. Considering the prop of bialgebras fails also: there is no guarantee that the comultiplication maps to the diagonal. For a concrete example, consider:

$$\begin{array}{ll}
 1 \mapsto N & \nabla \mapsto + = \lambda(x, y) : X \times X. x + y \\
 \top \mapsto \lambda x : \{\star\} : 0 & \Delta \mapsto \nabla^{op} \\
 \perp \mapsto \top^{op} &
 \end{array} \tag{2}$$

Here, the properties of addition of N , a ring without negatives, ensure that the bialgebra equations are satisfied; in particular, if $x + y = 0$, then $x = y = 0$.

We could require, for props that have a commutative comonoid structure that defines a product, that the product structure be preserved, so that Δ is mapped to the diagonal. Unfortunately, this would preclude considering \mathbf{Rel}_\times as a universe of models, since the monoidal product in \mathbf{Rel}_\times is *not* a cartesian product (recall that \mathbf{Rel} actually has $+$ as biproduct). Indeed, when interpreted in \mathbf{Rel} , the general form of Equations (1)

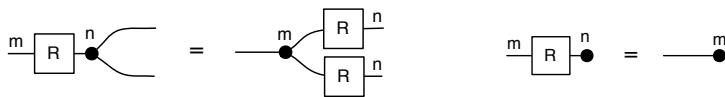

tells us that R is single-valued and total, which is true only of those relations that are (the graphs¹ of total) functions.

A crucial observation to make at this point is that products play *two* different roles in functorial semantics à la Lawvere. The first assures that the underlying data can be copied and deleted. This means the assumption of a “classical universe” and such an assumption excludes dealing with quantum data [22, 20]. We will not consider this aspect in the present paper. The second role is *preservation of arities*, the idea that one should be able to specify algebraic operations on a set or an object in a cartesian category. This second role concerns us here.

In particular, cartesian products are generalized to *lax cartesian products*, which Carboni and Walters [18] identified as important for the algebra of categories of relations. Indeed, the monoidal product of \mathbf{Rel}_\times satisfies a lax universal property. In practice this turns out to be, bureaucratically speaking, quite a tame notion of laxness: the 2-dimensional structure of \mathbf{Rel}_\times is posetal (set inclusion), and indeed we will concentrate on the poset-enriched case. At specification level, this means that it’s natural to introduce *inequations* between terms.

¹The graph of a function $f : X \rightarrow Y$ is the relation $\{(x, f(x)) : x \in X\} \subseteq X \times Y$.

In fact, the most we can say about relations R , in general, is that they are lax comonoid homomorphisms:

$$\begin{array}{c} m \\ \text{---} \\ \boxed{R} \\ \text{---} \\ n \end{array} \begin{array}{c} \text{---} \\ \text{---} \\ \bullet \\ \text{---} \\ \text{---} \end{array} \leq \begin{array}{c} \text{---} \\ \bullet \\ \text{---} \end{array} \begin{array}{c} \boxed{R} \\ \text{---} \\ \boxed{R} \\ \text{---} \\ n \end{array} \quad \begin{array}{c} m \\ \text{---} \\ \boxed{R} \\ \text{---} \\ n \end{array} \bullet \leq \text{---} \bullet \quad (3)$$

If *all* arrows are lax homomorphisms in this sense then the monoidal product is a lax product. Crucially, (3) holds in \mathbf{Rel}_X , where X -multiplication is the diagonal relation $\{(x, (x, x)) : x \in X\}$, that is, the graph of the diagonal function. Recall that, in \mathbf{Rel}_X , the Inequations (3) are strict exactly when, respectively, R is not single valued and not total.

1.3 Lax product theories

By a *lax product theory* we mean a generalisation of SMT that replaces equations with inequations, and includes a chosen commutative comonoid structure. Moreover, we require Inequations (3) that say that all other data is a lax comonoid homomorphism. We call the comonoid structure together with the aforementioned inequations a *lax product structure*. Every lax product theory leads to a free ordered prop (a prop enriched in the category or posets and monotone maps), where (3) ensure that the monoidal product is a lax product, in the bicategorical sense.

Specification	lax product theory
Syntax	string diagrams
Category	lax product 2-prop
Models	lax product structure preserving functors
Homomorphisms	monoidal lax natural transformations

Note that both the SMT of bialgebras and Hopf algebras are lax product theories (each equation is replaced by two inequations). And we now obtain a satisfactory “resource sensitive” generalisation of Lawvere’s functorial semantics to \mathbf{Rel} -models. For example, the models of the SMT of bialgebras, given by lax product structure preserving functors to \mathbf{Rel}_X , are exactly commutative monoids. This may appear surprising, since we are mapping to \mathbf{Rel}_X , one could expect that ∇ may map to an arbitrary relation. Instead, the fact that we need to preserve lax products means, since ∇ is functional in the specification, it maps to a function in the model. Moreover, the *categories* of models (where morphisms between models are given by monoidal natural transformations) coincide: both are the category of commutative monoids and homomorphisms. Thus the problem of (2) is avoided.

Yet lax product theories are not quite expressive enough for our purposes. We have seen that, using the lax product structure, we can express equationally when a relation is a function. But we cannot, for instance, say when a relation is a “co-function”, that is, the opposite relation of a function. This capability is very useful in examples, for example for the calculus of fractions in the SMT of Interacting Hopf Algebras [13].

1.4 Frobenius theories

A Frobenius theory – a concept introduced in this paper – is a lax product theory that includes additionally a “black” commutative monoid right adjoint to the comonoid:

$$\begin{array}{ccc}
 \text{---} & \leq & \text{---} \circlearrowleft \text{---} \\
 \text{---} & \leq & \text{---} \bullet \bullet \text{---} \\
 \text{---} & & \text{---} \bullet \bullet \text{---} \leq \text{id}_0
 \end{array}
 \qquad
 \begin{array}{ccc}
 \text{---} \circlearrowright \text{---} & \leq & \text{---} \\
 \text{---} \bullet \bullet \text{---} & \leq & \text{---}
 \end{array}
 \tag{4}$$

In general, a relation with a right adjoint is a function: the two inclusions in the first line of (4) respectively say that the comonoid operation is total and single-valued; the two inclusions in the second line that its unit is total and single-valued. The crucial law that makes the comonoids and the dual monoids into a Frobenius theory is comprised of the *Frobenius* equations (first line) and the *special* inequality (second line):

$$\begin{array}{ccc}
 \text{---} \circlearrowright \text{---} & = & \text{---} \bullet \bullet \text{---} \\
 \text{---} \bullet \bullet \text{---} & = & \text{---} \circlearrowleft \text{---}
 \end{array}
 \tag{5}$$

$$\text{---} \circlearrowleft \text{---} \leq \text{---}
 \tag{6}$$

The special inequality says that the monoid is single-valued. Together with the reverse inequality at the top left of (4), it gives the special *equality*, which says that the comultiplication postcomposed with the multiplication is the identity. The Frobenius equations, on the other hand, say that the multiplication postcomposed with the comultiplication can be decomposed in two ways, providing two interpolants [46, Section 4]. The equivalent forms, justifying Lawvere’s attribution to Frobenius [38], assert stability of inverse images under direct images [42] and allow abstraction in monoidal categories [44, Theorem 4.3]. Without the constraint that the comonoid is single-valued, the Frobenius equations in the monoidal category \mathbf{Rel}_x of relations over sets precisely characterize abelian groups [43]. In the monoidal category \mathbf{PRel}_x of relations over partial orders, they characterize Lambek’s pregroups [36, 46] and play an important role in modern theory of language and logic [17, 37, 50]. Together with the special law, the Frobenius equations induce the spider theorem, which implies that the mirror images of (3) hold, i.e. that, with respect to Frobenius algebras, relations are not only lax comonoid homomorphisms but also lax monoid homomorphisms:

$$\begin{array}{ccc}
 \text{---} \bullet \bullet \text{---} \text{---} \boxed{R} \text{---} & \leq & \text{---} \boxed{R} \text{---} \bullet \bullet \text{---} \\
 \text{---} \bullet \bullet \text{---} \text{---} \boxed{R} \text{---} & \leq & \text{---} \bullet \bullet \text{---}
 \end{array}$$

Frobenius algebras with single-valued comonoids, making the monoidal structure lax cartesian, were studied in the seminal paper [18] by Carboni and Walters. The free

ordered prop induced by (4) and (5) is what we refer to as a Frobenius prop (frop) or a Carboni–Walters category. Indeed, it is an example of Carboni–Walters’ bicategory of relations [18, Section 2]: a cartesian bicategory where the “black” structure satisfies the Frobenius equations. Discarding the 2-structure yields a hypergraph category (also known as well-supported compact closed category).

Specification	Frobenius theory
Syntax	string diagrams
Category	Carboni–Walters category
Models	lax product preserving functors
Homomorphisms	monoidal lax natural transformations

The frop of commutative monoids can be thought of as the prop of bialgebras, together with an additional commutative “black” monoid. Again, as in the case of lax product theories, the models in \mathbf{Rel}_\times are ordinary commutative monoids, and the model transformations are monoid homomorphisms. The example of commutative monoids generalises to arbitrary algebraic theories: there is a procedure, analogous to that of producing an SMT from a classical algebraic theory, that results in a Frobenius theory, so that the models of the relevant Lawvere category in \mathbf{Set} are in bijective correspondence with the models of the Frobenius theory in \mathbf{Rel}_\times . More than that, the categories of models are equivalent.

But Frobenius theories give us much more than a way of doing “resource-honest” algebraic theories in \mathbf{Rel}_\times : they are much more expressive and allow us to bring many new examples into the fold. This paper introduces the basic theory together with a wide range of examples.

1.5 From Manoa to Punaauia

During 2016 and 2017, the first and third authors made several research visits to the second author at the University of Hawaii at Manoa. Frobenius algebras had previously been used as an important tool in categorical models of computation, whether to separate the nondeterministic from the probabilistic models, and classical from quantum [20, 43], or to characterize computational bases in vector spaces [23], or as the centerpiece of data services in categorical computers [45]. The visits brought together our complementary toolkits. The present paper was drafted as a research report of some of the work that we did together and it was posted on arXiv in 2017. Although never submitted for publication, the draft garnered a number of citations, and led to further work, including four Ph.D. theses [51, 25, 41, 32] and several significant contributions [9, 10, 26, 8, 5, 31, 6] to theoretical computer science. The use of monoidal structures in theory and practice computation turned out to be convenient for teaching and led to a monograph [47], superseding [45] and giving new insights on foundational results of computability theory, while at the same time making the subject suitable for an undergraduate level course.

In 2023, while the first author was visiting the University of French Polynesia in Punaauia, this research culminated in the introduction of the first-order bicategory [4],

which can be seen as an extension of the Frobenius theory presented in this work, expanding it into a full first-order framework.

We consider this paper a humble offering of gratitude for the inspiration provided by Polynesia and its academic environment.

1.6 Structure of the Paper

We recall symmetric monoidal theories and props in Section 2 and explain how classical algebraic theories can be considered as symmetric monoidal theories, and the corresponding Lawvere theories as certain props. In Section 3 we extend the picture to inequational theories, resulting in poset-enriched props. We also identify the crucial concept of lax product structure, which allows us to keep the “arity-preservation” property of classical models. In Section 4 we introduce the central concept of Frobenius theory, describe models, and focus on some general properties. In Section 5, we highlight interesting examples of Frobenius theories, showcasing the expressivity of the framework. In Section 6 we explain how cartesian theories can be considered as Frobenius theories, without altering the category of models. The last sections are in-depth looks at three ubiquitous mathematical theories, considered as Frobenius theories: commutative monoids (Section 7), abelian groups (Section 8), and modules (Section 9).

2 Symmetric monoidal theories and props

Our exposition is founded on *symmetric monoidal theories*: presentations of algebraic structures borne by objects in a symmetric monoidal category.

Definition 2.1. A (presentation of a) symmetric monoidal theory (SMT) is a pair $\mathbb{T} = (\Sigma, E)$ consisting of a signature Σ and a set of equations E . The signature Σ is a set of generators $o : n \rightarrow m$ with arity n and coarity m . The set of Σ -terms is obtained by composing generators in Σ , the units $\text{id}_0 : 0 \rightarrow 0$, $\text{id}_1 : 1 \rightarrow 1$, and the symmetry $\sigma_{1,1} : 2 \rightarrow 2$ with $;$ and \oplus . This is a purely formal process: given Σ -terms $t : k \rightarrow l$, $u : l \rightarrow m$, $v : m \rightarrow n$, one constructs new Σ -terms $t ; u : k \rightarrow m$ and $t \oplus v : k + n \rightarrow l + n$. The set E of equations contains pairs $(t, t' : n \rightarrow m)$ of Σ -terms with the same arity and coarity.

The categorical concept associated with symmetric monoidal theories is the notion of prop (product and permutation category [40]).

Definition 2.2. A prop is a symmetric strict monoidal category with objects the natural numbers, where \oplus on objects is addition. The prop freely generated by a theory $\mathbb{T} = (\Sigma, E)$, denoted by $\mathcal{P}_{\mathbb{T}}$, has as its set of arrows $n \rightarrow m$ the set of Σ -terms $n \rightarrow m$ taken modulo the laws of symmetric strict monoidal categories (displayed in Figure 1), and the smallest congruence (with respect to $;$ and \oplus) containing equations $t = t'$ for any $(t, t') \in E$.

There is a natural graphical representation for arrows of a prop as string diagrams, which we now sketch, referring to [52] for the details. A Σ -term $n \rightarrow m$ is pictured as

$$\begin{aligned}
 (t_1 ; t_3) \oplus (t_2 ; t_4) &= (t_1 \oplus t_2) ; (t_3 \oplus t_4) \\
 (t_1 ; t_2) ; t_3 &= t_1 ; (t_2 ; t_3) & \text{id}_n ; c &= c = c ; \text{id}_m \\
 (t_1 \oplus t_2) \oplus t_3 &= t_1 \oplus (t_2 \oplus t_3) & \text{id}_0 \oplus t &= t = t \oplus \text{id}_0 \\
 \sigma_{1,1} ; \sigma_{1,1} &= \text{id}_2 & (t \oplus \text{id}_z) ; \sigma_{m,z} &= \sigma_{n,z} ; (\text{id}_z \oplus t)
 \end{aligned}$$

Figure 1: Axioms of symmetric strict monoidal categories for a prop \mathbb{T} .

a box with n ports on the left and m ports on the right. Composition via $;$ and \oplus are rendered graphically by horizontal and vertical juxtaposition of boxes, respectively:

$$t ; s \text{ is drawn } \boxed{t} \boxed{s} \qquad t \oplus s \text{ is drawn } \begin{array}{|c|} \hline t \\ \hline s \\ \hline \end{array}$$

In any SMT there are specific Σ -terms generating the underlying symmetric monoidal structure: these are $\text{id}_1 : 1 \rightarrow 1$, represented as \square , the symmetry $\sigma_{1,1} : 1 + 1 \rightarrow 1 + 1$, represented as \curvearrowright , and the unit object for \oplus , that is, $\text{id}_0 : 0 \rightarrow 0$, whose representation is an empty diagram. Graphical representation for arbitrary identities id_n and symmetries $\sigma_{n,m}$ can be generated inductively, we omit the details here.

Example 2.3.

- (a) We write $\text{CM} = (\Sigma_M, E_M)$ for the SMT of *commutative monoids*. The signature Σ_M contains a *multiplication* $\curvearrowright \circ - : 2 \rightarrow 1$ and a *unit* $\circ - : 0 \rightarrow 1$. The equations below form E_M and assert associativity (7), commutativity (8) and unitality (9).

$$\text{Diagram (7)} \qquad \qquad \qquad (7)$$

$$\text{Diagram (8)} \qquad \qquad \qquad (8)$$

$$\text{Diagram (9)} \qquad \qquad \qquad (9)$$

- (b) Dually, consider the SMT $\text{CC} = (\Sigma_C, E_C)$ of *commutative comonoids*. Its signature Σ_C consists of a *comultiplication* $- \curvearrowleft : 1 \rightarrow 2$ and a *counit* $- \bullet : 1 \rightarrow 0$. Its set of equations E_C consists of:

$$\text{Diagram (10)} \qquad \qquad \qquad (10)$$

$$\text{Diagram (11)} \qquad \qquad \qquad (11)$$

$$\text{Diagram (12)} \qquad \qquad \qquad (12)$$

- (c) Monoids and comonoids can be combined into a theory that plays an important role in our exposition: the theory of *special Frobenius algebras* [18]. This is given by $\mathbb{F} = (\Sigma_M \uplus \Sigma_C, E_M \uplus E_C \uplus F)$, where F consists of the equations:

$$\text{Diagram 1} = \text{Diagram 2} = \text{Diagram 3} \tag{13}$$

$$\text{Diagram 4} = \text{Diagram 5} \tag{14}$$

- (d) Another fundamental way to combine monoids and comonoids is the theory of (commutative/cocommutative) *bialgebras* $\mathbb{B} = (\Sigma_M \uplus \Sigma_C, E_M \uplus E_C \uplus B)$, where B consists of the equations:

$$\text{Diagram 6} = \text{Diagram 7} \tag{15}$$

$$\text{Diagram 8} = \text{Diagram 9} \tag{16}$$

$$\text{Diagram 10} = \text{Diagram 11} \tag{17}$$

$$\text{Diagram 12} = \text{id}_0 \tag{18}$$

One can read (15)–(18) as stating that the monoid structure (multiplication, unit) is a comonoid homomorphism, and vice versa, the comonoid structure is a monoid homomorphism.

Bialgebras and special Frobenius algebras play an important role in recent research threads in quantum [19, 12], concurrency [16, 53] and control theory [11, 2, 14].

- (e) Another theory that plays a crucial role in the aforementioned works is the theory \mathbb{H} of *Hopf algebras*. It is obtained from the theory of bialgebra by extending the signature $\Sigma_M \uplus \Sigma_C$ with the *antipode* \blacksquare : $1 \rightarrow 1$ and the set of equations $E_M \uplus E_C \uplus B$ with the three equations:

$$\text{Diagram 13} = \text{Diagram 14} \tag{19}$$

$$\text{Diagram 15} = \text{Diagram 16} \tag{20}$$

$$\text{Diagram 17} = \text{Diagram 18} \tag{21}$$

The assertion that CM is the SMT of commutative monoids – and similarly for other SMTs in our exposition – can be made precise through the notion of *model* of an SMT.

Definition 2.4. Given a symmetric monoidal category \mathbf{C} , a model of an SMTT in \mathbf{C} is a symmetric monoidal functor $F : \mathcal{P}_{\mathbb{T}} \rightarrow \mathbf{C}$. Then $\text{Mod}_{\text{SMT}}(\mathbb{T}, \mathbf{C})$ is the category of models of \mathbb{T} in \mathbf{C} and monoidal natural transformations between them.

Turning to commutative monoids, there is a category $\text{Monoid}(\mathbf{C})$ whose objects are the commutative monoids in \mathbf{C} , i.e., objects $x \in \mathbf{C}$ equipped with arrows $x \oplus x \rightarrow x$ and $I \rightarrow x$, satisfying the usual equations. Given any model $F : \mathcal{P}_{\text{CM}} \rightarrow \mathbf{C}$, it follows that $F1$ is a commutative monoid in \mathbf{C} : this yields a functor $\text{Mod}_{\text{SMT}}(\mathcal{P}_{\text{CM}}, \mathbf{C}) \rightarrow \text{Monoid}(\mathbf{C})$. Saying that (Σ_M, E_M) is the SMT of commutative monoids means that this functor is an equivalence natural in \mathbf{C} .

We can recover classical models by considering symmetric monoidal functors to Set_{\times} , the symmetric monoidal category of sets, where the monoidal product is the cartesian product \times . Indeed, the functor is determined, up-to natural isomorphism, by where it sends 1. Concretely, we can consider the image of a symmetric monoidal functor of this type to consist of the sets of n -tuples $n \mapsto X^n \stackrel{\text{def}}{=} \{(x_1, \dots, x_n) : x_i \in X\}$, where $X = F1$. Then $\text{Monoid}(\text{Set}_{\times})$ is equivalent to the category of ordinary commutative monoids and monoid homomorphisms.

2.1 Cartesian theories and Lawvere categories

A *cartesian category* (or finite product category) is a symmetric monoidal category where the monoidal product \oplus satisfies the universal property of the categorical product; a cartesian functor is a product preserving functor. It is well-known [28] that a symmetric monoidal category \mathbf{C} is cartesian if and only if, for every object n in \mathbf{C} , there are arrows $\Delta_n : n \rightarrow n \oplus n$ and $!_n : n \rightarrow I$ forming a cocommutative comonoid, graphically denoted by $\text{---} \overset{n}{\curvearrowright}$ and $\text{---} \overset{n}{\bullet}$, and every arrow $f : m \rightarrow n$ in \mathbf{C} is a comonoid homomorphism:

$$\begin{array}{c} \text{---} \overset{m}{\boxed{f}} \overset{n}{\curvearrowright} = \text{---} \overset{m}{\bullet} \begin{array}{l} \overset{n}{\boxed{f}} \\ \text{---} \overset{n}{\bullet} \end{array} \\ \text{---} \overset{m}{\boxed{f}} \overset{n}{\bullet} = \text{---} \overset{m}{\bullet} \end{array}$$

A *Lawvere category* [39, 33] is then a symmetric monoidal category that is both cartesian and a prop.

Example 2.5.

- (a) Recall the theory of commutative comonoids $\text{CC} = (\Sigma_C, E_C)$ from Example 2.3(b). The resulting prop \mathcal{P}_{CC} is the initial Lawvere category, the free category with products on one object. The comultiplication $\text{---} \overset{1}{\curvearrowright} : 1 \rightarrow 2$ and the counit $\text{---} \overset{1}{\bullet} : 1 \rightarrow 0$ are the comonoid on 1. For $n \in \mathbb{N}$, $\Delta_n : n \rightarrow n \oplus n$ and $!_n : n \rightarrow 0$ are defined recursively: $\Delta_0 = \text{id}_0$ and $\Delta_{n+1} = (\Delta_1 \oplus \Delta_n) ; (\text{id}_1 \oplus \sigma_{1,n} \oplus \text{id}_n)$, $!_0 = \text{id}_0$ and $!_{n+1} = !_1 \oplus !_n$.
- (b) The prop of *bialgebras* $\mathcal{P}_{\mathbb{B}}$ (Example 2.3(c)) is also a Lawvere category. For every natural number, the comonoid structure is defined as above. Moreover all arrows in

\mathcal{P}_B are comonoid homomorphisms, since (15), (16), (17), (18) say exactly that \triangleright and \circ are comonoid homomorphisms.

- (c) Amongst the other SMTs in Example 2.3, only \mathbb{H} freely generates a Lawvere category: indeed Equations (19) and (20) state that the antipode is a comonoid homomorphism.

Definition 2.6. A (presentation of a) cartesian theory is a pair $\mathbb{T} = (\Sigma, E)$ consisting of a signature Σ and equations E . Σ is a set of generators $o : n \rightarrow 1$ with arity n and coarity 1. The set of equations E contains pairs $(t, t' : n \rightarrow 1)$ of cartesian Σ -terms, namely arrows of the prop freely generated by the SMT $(\Sigma \uplus \Sigma_C, E_C \uplus E_{CH})$ where E_{CH} contains equations

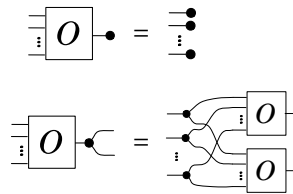

for each generator $\boxed{O} : n \rightarrow 1$ of the signature Σ .

The Lawvere category freely generated by a cartesian theory $\mathbb{T} = (\Sigma, E)$, denoted by $\mathcal{L}_{\mathbb{T}}$, is the prop freely generated by the SMT $(\Sigma \uplus \Sigma_C, E \uplus E_C \uplus E_{CH})$. The latter will be often referred to as the SMT corresponding to the cartesian theory (Σ, E) .

Cartesian terms can be thought as the familiar notion of standard syntactic term: trees with leaves labeled by variables. The ability to copy and discard variables is given by \bullet and \circ , respectively. Since these structures are implicit in any cartesian theory, one can therefore think of cartesian terms as *resource-insensitive* syntax. On the other hand, the string diagrams of SMTs provide a resource-aware syntax since the ability to add and copy variables, if available, is made explicit.

Example 2.7.

- (a) In Σ -terms of the SMT of commutative monoids $\mathbb{CM} = (\Sigma_M, E_M)$ (Example 2.3(a)), variables cannot be copied or discarded. The cartesian theory of commutative monoids has the same signature and equations, but terms have the implicit capability of being copied and discharged. Indeed, the Lawvere category $\mathcal{L}_{\mathbb{CM}}$ is isomorphic to the prop \mathcal{P}_B generated by the SMT of bialgebras (Example 2.3(d)).
- (b) By adding to \mathbb{CM} the antipode \dashv : $1 \rightarrow 1$ and Equation (21), one obtains the cartesian theory \mathbb{AG} of abelian groups. The corresponding SMT is the theory \mathbb{H} of Hopf algebras (Example 2.3(e)): i.e. $\mathcal{P}_{\mathbb{H}} \cong \mathcal{L}_{\mathbb{AG}}$.

As for SMTs, the assertion that \mathbb{CM} is the cartesian theory of commutative monoids can be made precise using the notion of *model* of a cartesian theory.

Definition 2.8. Given a cartesian category \mathbb{C} , a model of a cartesian theory \mathbb{T} in \mathbb{C} is a cartesian functor $F : \mathcal{L}_{\mathbb{T}} \rightarrow \mathbb{C}$. Then $\text{Mod}_{\text{CAR}}(\mathbb{T}, \mathbb{C})$ is the category of models of \mathbb{T} in \mathbb{C} and monoidal natural transformations between them.

For an example take the cartesian category \mathbf{Set} . Every model $F : \mathcal{L}_{\mathbb{T}} \rightarrow \mathbf{Set}$ maps 1 to some set X and thus every natural number n to X^n . Requiring F to be cartesian forces the counit $\bullet : 1 \rightarrow 0$ to be mapped into the unique morphism from X to the final object $1 = X^0$ and the comultiplication $\blacktriangleleft : 1 \rightarrow 2$ to the diagonal $\Delta_X = \langle \text{id}_X, \text{id}_X \rangle : X \rightarrow X \times X$. So, a model F is uniquely determined by the set $F1$ and the functions $Fo : (F1)^n \rightarrow F1$ for each generator $o : n \rightarrow 1$ of the signature. In a nutshell, the notion of cartesian model for \mathbb{T} coincides with the standard notion of algebra. By spelling out the definition of natural transformation, one can readily check that morphism of models are homomorphisms.

3 Lax product theories

A first step toward Frobenius theories and their models consists in relaxing products and considering lax products instead. In this section, we introduce the categorical machinery to deal with theories of inequations and lax products theories.

Definition 3.1. *Suppose that Σ is a set of generators and I is a set of inequations: similarly to an equation, the underlying data of an inequation is simply a pair (t_1, t_2) of equal-typed Σ -terms. Unlike equations, however, we will understand this data as being directed:*

$$t_1 \leq t_2$$

We call the pair (Σ, I) a (presentation of a) symmetric monoidal inequation theory (SMIT).

Throughout the paper we use *ordered* as a synonym for “enriched in \mathbf{Pos} ” - the category of posets and monotonic functions. Indeed, just as SMTs lead to props, SMITs lead to ordered props, as defined below.

Definition 3.2 (Ordered prop). *An ordered prop is a prop enriched over the category of posets: that is, it is a strict symmetric 2-category \mathbf{C} with objects the natural numbers, monoidal product on objects defined as $m \oplus n \stackrel{\text{def}}{=} m + n$, where each set of arrows $\mathbf{C}[m, n]$ is a poset, with composition and monoidal product monotonic. Similarly, a pre-ordered prop is a prop enriched over the category of pre-orders.*

We have seen how an SMT (Σ, E) yields a free prop. Analogously, from a SMIT (Σ, I) one can generate a free ordered prop. First, we construct the free pre-ordered prop whose arrows are Σ -terms. The hom-set orders are determined by whiskering I and closing it under \oplus , then applying reflexive and transitive closure: this is the smallest preorder containing I that makes \mathbf{C} into a pre-ordered prop (i.e. composition is monotonic and \oplus is a 2-functor). Then, we obtain the free ordered prop by quotienting the free pre-ordered prop by the equivalence induced by the pre-order; in other words, forcing antisymmetry by equating terms s, t where $s \leq t$ and $t \leq s$.

Any SMT (Σ, E) gives rise to a canonical SMIT (Σ, I) where each equation is replaced with two inequalities $I = E \uplus E^{op}$, in the obvious way. The free prop for (Σ, E) can then be obtained from the free ordered prop for (Σ, I) by forgetting the underlying 2-structure. For this reason, we can safely abuse the notation $\mathcal{P}_{\mathbb{T}}$ to denote the ordered prop freely generated by a SMIT \mathbb{T} .

Example 3.3.

- (a) The SMT of commutative monoids $\mathbb{CM} = (\Sigma_M, E_M)$ (Example 2.3(a)) can be regarded as the SMIT $(\Sigma_M, E_M \uplus E_M^{op})$.
- (b) The SMT of cocommutative comonoids $\mathbb{CC} = (\Sigma_C, E_C)$ (Example 2.3(b)) can be regarded as the SMIT $(\Sigma_C, E_C \uplus E_C^{op})$.
- (c) The SMT of bialgebra $\mathbb{B} = (\Sigma_M \uplus \Sigma_C, E_M \uplus E_C \uplus B)$ (Example 2.3(d)) can be regarded as the SMIT $(\Sigma_M \uplus \Sigma_C, E_M \uplus E_M^{op} \uplus E_C \uplus E_C^{op} \uplus B \uplus B^{op})$.
- (d) From the SMIT of bialgebra, one can drop the inequations B^{op} and obtain the SMIT of *lax bialgebras* $\mathbb{LB} = (\Sigma_M \uplus \Sigma_C, E_M \uplus E_M^{op} \uplus E_C \uplus E_C^{op} \uplus B)$. In this theory, we have a monoid, a comonoid, and the inequations of B :

$$\text{Diagram 1} \leq \text{Diagram 2} \tag{22}$$

$$\text{Diagram 3} \leq \text{Diagram 4} \tag{23}$$

$$\text{Diagram 5} \leq \text{Diagram 6} \tag{24}$$

$$\text{Diagram 7} \leq \text{id}_0 \tag{25}$$

These force the monoid to be a lax comonoid homomorphism.

- (e) Alternatively, one can drop the inequations in B and obtains the SMIT of *oplax bialgebras* $\mathbb{OLB} = (\Sigma_M \uplus \Sigma_C, E_M \uplus E_M^{op} \uplus E_C \uplus E_C^{op} \uplus B^{op})$. The inequations of B^{op} are:

$$\text{Diagram 1} \geq \text{Diagram 2} \tag{26}$$

$$\text{Diagram 3} \geq \text{Diagram 4} \tag{27}$$

$$\text{Diagram 5} \geq \text{Diagram 6} \tag{28}$$

$$\text{Diagram 7} \geq \text{id}_0 \tag{29}$$

Particularly relevant for our exposition is the SMIT of commutative comonoids: cartesian theories include an implicit comonoid structure and force the generators in the signature to be comonoid homomorphisms. The theories that we are going to introduce next – lax product theories – are analogous, but they require the generators to be *lax* comonoid homomorphisms.

Definition 3.4 (Lax product theory, LPT). A (presentation of a) lax product theory is a pair $\mathbb{T} = (\Sigma, I)$ consisting of a signature Σ and a set of inequations I . The signature Σ is a set of generators $\sigma : n \rightarrow m$ with arity n and coarity m . The set of inequations I contains pairs $(t, t' : n \rightarrow m)$ of L - Σ -terms, namely arrows of the ordered prop freely generated by the SMIT $(\Sigma \uplus \Sigma_C, E_C \uplus E_C^{op} \uplus I_{LCH})$ where I_{LCH} is the set containing

$$\begin{array}{c} m \\ \square \\ \sigma \\ \bullet \\ \begin{array}{l} \nearrow \\ \searrow \end{array} \\ n \end{array} \leq \begin{array}{c} \begin{array}{l} \square \\ \sigma \\ \square \end{array} \\ \bullet \\ \begin{array}{l} \nearrow \\ \searrow \end{array} \\ m \\ n \end{array} \tag{30}$$

$$\begin{array}{c} m \\ \square \\ \sigma \\ \bullet \\ n \end{array} \leq \begin{array}{c} m \\ \bullet \end{array} \tag{31}$$

for each generator σ in Σ .

We refer to $(\Sigma \uplus \Sigma_C, I \uplus E_C \uplus E_C^{op} \uplus I_{LCH})$ as the SMIT corresponding to an LPT $\mathbb{T} = (\Sigma, I)$. The ordered prop freely generated by the SMIT corresponding to \mathbb{T} is called the lax product prop freely generated by \mathbb{T} and denoted by $\mathcal{LP}_{\mathbb{T}}$.

The mismatch between and SMITs and LPTs is akin to the one of SMTs and cartesian theories: the theory of comonoids (Example 3.3(b)) is the SMIT corresponding to the empty LPT (\emptyset, \emptyset) ; the theory of lax bialgebra (Example 3.3(d)) is the SMIT corresponding to the LPT of commutative monoids (Example 3.3(a)).

An important difference between lax product theories and cartesian theories is that generators in Σ can have arbitrary coarity, not necessarily 1 as is the case in any cartesian theory. Indeed, the presence of finite products eliminates the need for coarities other than 1, since to give an arrow $X^m \rightarrow X^n$ in a cartesian category is to give an n -tuple of arrows $X^m \rightarrow X$, obtained by composing with the projections. In a lax product category, instead, this is not the case. As we shall see below, the category of relations can be considered as a source of models for a lax product theory and it is clearly not true, in general, that relations $X^m \rightarrow X^n$ are determined by their projections.

The notion of lax product prop will be formalised in the next subsection. For the moment, the reader can think of these structures as ordered props where objects are equipped with a comonoid structure and arrows are lax comonoid homomorphism. This is the case in $\mathcal{LP}_{\mathbb{T}}$ as shown below.

Theorem 3.5. Let $\mathbb{T} = (\Sigma, I)$ be an LPT and $\mathcal{LP}_{\mathbb{T}}$ be the lax product prop freely generated by it. Then every $t : m \rightarrow n$ in $\mathcal{LP}_{\mathbb{T}}$ is a lax comonoid homomorphism.

Proof. By Inequations (30) and (31), every generator in Σ is a lax comonoid homomorphism. A simple structural induction extends this property to compound terms:

$$\begin{array}{c} p \\ \square \\ t_1 \\ q \\ \square \\ t_2 \\ \bullet \\ r \end{array} \leq \begin{array}{c} \begin{array}{l} \square \\ t_2 \\ \square \end{array} \\ \bullet \\ \begin{array}{l} \square \\ t_1 \\ \square \end{array} \\ p \\ q \\ r \end{array} \leq \begin{array}{c} \begin{array}{l} \square \\ t_1 \\ \square \end{array} \\ \bullet \\ \begin{array}{l} \square \\ t_2 \\ \square \end{array} \\ p \\ q \\ r \end{array}$$

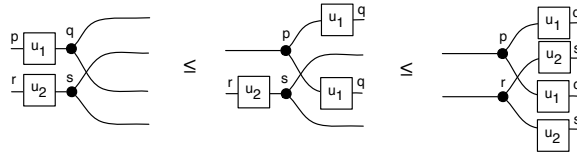

□

3.1 Lax product structures and lax products

In Section 2.1 we recalled that the monoidal product is a categorical product precisely when all arrows are comonoid homomorphisms. Here we show that the property of arrows being lax-comonoid homomorphisms force the monoidal product to be a lax product, a bicategorical limit. First, we note that the commutative comonoid structure in any lax product theory is an instance of something we call a *lax product structure*.

Definition 3.6 (Lax product structure). *Given an ordered monoidal category \mathcal{C} , a lax product structure is a choice, for each object $C \in \mathcal{C}$, of commutative comonoid (Δ_C, \perp_C) , compatible with the monoidal product in the obvious way, i.e.*

$$\Delta_{C \oplus D} = (\Delta_C \oplus \Delta_D); (C \oplus \sigma_{C,D} \oplus D) \quad \perp_{C \oplus D} = \perp_C \oplus \perp_D,$$

such that, for every arrow $\alpha : B \rightarrow C$, we have

$$\alpha; \Delta_C \leq \Delta_B; (\alpha \oplus \alpha) \quad \text{and} \quad \alpha; \perp_C \leq \perp_B.$$

Lemma 3.7. *In an ordered monoidal category \mathcal{C} , a lax product structure, if it exists, is unique.*

Proof. Consider lax product structures $\{(\Delta_C, \perp_C) : C \in \mathcal{C}\}$ and $\{(\Delta'_C, \perp'_C) : C \in \mathcal{C}\}$ which we shall draw $(\text{---} \curvearrowright, \text{---} \bullet)$ and $(\text{---} \curvearrowright, \text{---} \blacksquare)$, respectively. It follows that, for all C , we have $\perp_C = \perp'_C$ since $\perp'_C \leq \perp_C$; indeed

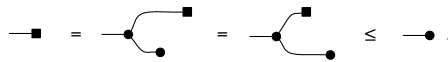

The first equality uses unitality, the second is interchange in a monoidal category, and the third is (31). Using a symmetric argument, we deduce $\perp_C \leq \perp'_C$. Since the lax product structure is, by definition, assumed to be compatible with monoidal product and since $\perp_C = \perp'_C$ we have $\Delta'_C \leq \Delta_C$ by

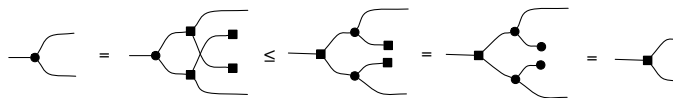

and, again by a symmetric argument, we conclude $\Delta_C \leq \Delta'_C$.

□

We will now show that, if an ordered monoidal category has a lax product structure, then the monoidal product is a lax product, by which we mean the following bicategorical limit. Given objects m and n , a *lax product* is an object $m \times n$ with *projections*, that is arrows $\pi_1 : m \times n \rightarrow m, \pi_2 : m \times n \rightarrow n$ such that, for any $f : k \rightarrow m, g : k \rightarrow n$, there exists $h : k \rightarrow m \times n$ and 2-cells ρ_1, ρ_2 satisfying

$$\begin{array}{ccc}
 m & \xleftarrow{\pi_1} & m \times n & \xrightarrow{\pi_2} & n \\
 \uparrow & & \uparrow h & & \uparrow \\
 & \rho_1 \swarrow & \vdots & \searrow \rho_2 & \\
 & f & k & g &
 \end{array}
 \tag{32}$$

such that, given any other $h', \sigma_1,$ and σ_2 which verify

$$\begin{array}{ccc}
 m & \xleftarrow{\pi_1} & m \times n & \xrightarrow{\pi_2} & n \\
 \uparrow & & \uparrow h' & & \uparrow \\
 & \sigma_1 \swarrow & \vdots & \searrow \sigma_2 & \\
 & f & k & g &
 \end{array}$$

there exists a unique $\xi : h' \Rightarrow h$ such that

$$\begin{array}{ccc}
 m & \xleftarrow{\pi_1} & m \times n & & m & \xleftarrow{\pi_1} & m \times n \\
 \uparrow & & \uparrow h & \xleftarrow{\xi} & h' & & \uparrow \\
 & \rho_1 \swarrow & & & & \swarrow \sigma_1 & \\
 & f & k & & k & & f \\
 & & & & & & \uparrow h'
 \end{array}
 =$$

and

$$\begin{array}{ccc}
 m \times n & \xrightarrow{\pi_2} & n & & m \times n & \xrightarrow{\pi_2} & n \\
 \uparrow & & \uparrow h & \xrightarrow{\xi} & h' & & \uparrow \\
 & \rho_2 \swarrow & & & & \swarrow \sigma_2 & \\
 & f & k & & k & & f \\
 & & & & & & \uparrow h'
 \end{array}
 =$$

Theorem 3.8 (Carboni and Walters). *Suppose that \mathbf{C} has a lax product structure. Then the monoidal product of \mathbf{C} is a lax product.*

Proof. The projections are:

$$\pi_1 \stackrel{\text{def}}{=} \frac{m}{n \bullet} \qquad \pi_2 \stackrel{\text{def}}{=} \frac{\bullet}{n}$$

It is easy to show that the universal property holds. Indeed, given $f : k \rightarrow m$ and $g : k \rightarrow n$, we see that

$$h = \begin{array}{c} \bullet \\ \swarrow \quad \searrow \\ \boxed{f} \quad \boxed{g} \\ m \quad n \end{array}$$

gives us ρ_1 and ρ_2 (32) since

$$\begin{array}{c} \text{---} k \text{---} \\ \swarrow \quad \searrow \\ \boxed{f} \quad \boxed{g} \\ \uparrow \quad \downarrow \\ m \quad n \end{array} \leq \begin{array}{c} \text{---} k \text{---} \\ \swarrow \quad \searrow \\ \boxed{f} \quad \bullet \\ \uparrow \quad \downarrow \\ m \quad k \end{array} = \begin{array}{c} \text{---} k \text{---} \\ \boxed{f} \\ \text{---} m \end{array}$$

and, similarly,

$$\begin{array}{c} \text{---} k \text{---} \\ \swarrow \quad \searrow \\ \boxed{f} \quad \bullet \\ \uparrow \quad \downarrow \\ m \quad n \end{array} \leq \begin{array}{c} \text{---} k \text{---} \\ \boxed{g} \\ \text{---} n \end{array} .$$

Given any $h' : k \rightarrow m \oplus n$ with

$$\begin{array}{c} \text{---} k \text{---} \\ \boxed{h'} \\ \swarrow \quad \searrow \\ m \quad n \end{array} \leq \begin{array}{c} \text{---} k \text{---} \\ \boxed{f} \\ \text{---} m \end{array} \quad \text{and} \quad \begin{array}{c} \text{---} k \text{---} \\ \boxed{h'} \\ \swarrow \quad \searrow \\ m \quad n \end{array} \leq \begin{array}{c} \text{---} k \text{---} \\ \boxed{g} \\ \text{---} n \end{array}$$

we have

$$\begin{array}{c} \text{---} k \text{---} \\ \boxed{h'} \\ \swarrow \quad \searrow \\ m \quad n \end{array} = \begin{array}{c} \text{---} k \text{---} \\ \boxed{h'} \\ \swarrow \quad \searrow \\ m \quad n \end{array} \begin{array}{c} \text{---} m \text{---} \\ \swarrow \quad \searrow \\ \bullet \quad \bullet \\ \uparrow \quad \downarrow \\ m \quad n \end{array} \leq \begin{array}{c} \text{---} k \text{---} \\ \swarrow \quad \searrow \\ \boxed{h'} \quad \bullet \\ \uparrow \quad \downarrow \\ m \quad n \end{array} \leq \begin{array}{c} \text{---} k \text{---} \\ \swarrow \quad \searrow \\ \boxed{f} \quad \bullet \\ \uparrow \quad \downarrow \\ m \quad n \end{array} .$$

□

Corollary 3.9. *Let \mathbb{T} be a SMIT. Then in $\mathcal{LP}_{\mathbb{T}}$, the monoidal product is a lax product.*

Proof. By Theorem 3.5 we know that every arrow $\mathcal{LP}_{\mathbb{T}}$ is a lax comonoid homomorphism, thus the monoidal product is a lax product by Theorem 3.8. □

Corollary 3.10. *In \mathbf{Rel} , considered as a 2-category (the 2-cells are set inclusions), the cartesian product is a lax product.*

Proof. It suffices to show that every relation is a lax comonoid homomorphism. The lax product structure is then obtained as in the proof of Theorem 3.8. □

The appropriate notion of model for a lax product theory is a poset-enriched monoidal functor that preserves lax product structure, in the sense of Definition 3.6. The notion of homomorphism of models is then a lax monoidal natural transformation between such functors.

More concretely, we define a *lax product category* to be a symmetric monoidal category, enriched over the category of posets, that contains a lax product structure in the sense of Definition 3.6. A lax product prop is both an ordered prop and lax product category. A lax product functor is a poset-enriched functor that preserves the lax product structure. Fixing a lax product category C , models for an LPT \mathbb{T} are lax product functors $F : \mathcal{LP}_{\mathbb{T}} \rightarrow C$, and homomorphisms are lax monoidal natural transformations.

In order to avoid duplication, we postpone a more comprehensive discussion to Section 4, and first introduce *Frobenius theories*, which are a particularly interesting and expressive variant of lax product theories.

4 Frobenius theories and their models

In this section we introduce the main contribution of this work: Frobenius theories and their models. To this aim we recall the concept of *cartesian bicategories of relations* from [18] and flesh out some of their properties.

Recall that an arrow $f : B \rightarrow C$ in a 2-category has a right adjoint $g : C \rightarrow B$ when there exist 2-cells $\eta : \text{id}_B \rightarrow f ; g$ and $\varepsilon : g ; f \rightarrow \text{id}_C$ satisfying the well-known triangle equations. In the poset-enriched case, this simplifies to requiring merely

$$\text{id}_B \leq f ; g \quad g ; f \leq \text{id}_C . \tag{33}$$

In Section 3 we saw a particular emphasis on the SMT of commutative comonoids (Example 2.3(b)). According to (33), to define adjoints to the generators $\{ \text{---} \bullet \text{---} , \text{---} \bullet \}$, in a lax product theory, it suffices to add generators $\{ \text{---} \curvearrowright \text{---} , \bullet \text{---} \}$ and inequations of (4).

Next, recall from Example 2.3(c) that the SMT \mathbb{F} of special Frobenius monoids has, as set of generators, $\{ \text{---} \curvearrowright \text{---} , \bullet \text{---} , \text{---} \bullet \text{---} , \text{---} \bullet \}$ and, as equations, those that guarantee that the generators above form, respectively, a commutative monoid and commutative comonoid, together with the Frobenius equation and the special equation:

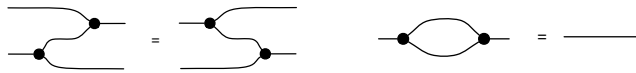

Succinctly, cartesian bicategories of relations are lax product categories where the lax product structure has right adjoints (a commutative monoid), satisfying the equations of special Frobenius monoids. We spell out the details below.

Definition 4.1. A cartesian bicategory of relations is a poset enriched category that is symmetric, monoidal, and satisfies the following conditions.

1. For every object n , there are arrows $\Delta_n : n \rightarrow n \oplus n$ and $!_n : n \rightarrow I$, graphically denoted by $\text{---} \overset{n}{\curvearrowright} \text{---}$ and $\text{---} \overset{n}{\bullet}$ forming a cocommutative comonoid.
2. For every object n , there are arrows $\nabla_n : n \oplus n \rightarrow n$ and $?_n : I \rightarrow n$, graphically denoted by $\text{---} \overset{n}{\curvearrowleft} \text{---}$ and $\text{---} \overset{n}{\bullet}$, forming a commutative monoid.
3. The monoids and the comonoids satisfy the five inequations:

$$\text{---} \overset{n}{\curvearrowright} \text{---} \overset{n}{\curvearrowleft} \text{---} \leq \text{---} \overset{n}{\text{---}} \tag{34}$$

$$\text{---} \overset{n}{\text{---}} \leq \text{---} \overset{n}{\curvearrowleft} \text{---} \overset{n}{\curvearrowright} \text{---} \tag{35}$$

$$\overset{n}{\bullet} \text{---} \overset{n}{\bullet} \leq \text{id}_0 \tag{36}$$

$$\text{---}^n \leq \text{---}^n \bullet \bullet \text{---}^n \tag{37}$$

$$\text{---}^n \text{---}^n \text{---}^n = \text{---}^n \text{---}^n \text{---}^n = \text{---}^n \text{---}^n \tag{38}$$

4. Every arrow $R : m \rightarrow n$ is a lax comonoid homomorphism:

$$\text{---}^m \text{---}^n \text{---}^n \leq \text{---}^m \text{---}^n \text{---}^n \tag{39}$$

$$\text{---}^m \text{---}^n \leq \text{---}^m \bullet \tag{40}$$

Inequations (34) and (35) state that $\text{---}^n \text{---}^n$ is the left adjoint of $\text{---}^n \text{---}^n$, while Inequations (36) and (37) state that $\text{---}^n \bullet$ is the left adjoint of ---^n . Note that Equation (38) is Equation (13) of Example 2.3(c) describing the SMT of special Frobenius algebras; its other Equation (14) holds in any cartesian bicategory of relations: one direction is given by (35) and the other is proved as follows.

$$\text{---}^n \text{---}^n \leq \text{---}^n \bullet \bullet \text{---}^n = \text{---}^n$$

Therefore, we will often refer to the monoid and the comonoid of a cartesian bicategory of relations \mathcal{C} as the (*special*) *Frobenius structure* of \mathcal{C} .

Since Condition 4 requires every arrow to be a lax comonoid homomorphism, we know by Theorem 3.8, that the monoidal product \oplus is a lax-product. This helps us in showing that \mathbf{Rel} is a cartesian bicategory of relations: indeed, from Corollary 3.10 we know that the lax product in \mathbf{Rel} is simply the cartesian one. Now for every set X , $\Delta_X : X \rightarrow X \times X$ is the diagonal relation $\{(x, (x, x)) : x \in X\}$, $!_X : X \rightarrow 1 = \{\bullet\}$ is the relation $\{(x, \bullet) : x \in X\}$, $\nabla_X : X \times X \rightarrow X$ and $!_X : 1 \rightarrow X$ are, respectively, their opposite relations. One can easily check that the inequations in Condition 3 hold.

A *cartesian bifunctor* is the notion of structure-preserving homomorphism between cartesian bicategories of relations. In fact, it suffices to require that the lax product structure, in the sense of Definition 3.6, is preserved, that is, the notion of cartesian bifunctor is the same as lax product functor. Indeed, the fact that adjoints are preserved follows from (2-)functoriality, since adjoints are uniquely defined in ordered categories.

Compact closed structure. In any cartesian bicategory of relations we have a self-dual compact closed structure. To describe it, we adopt the graphical notation:

$$\text{---} \text{---}^{\dagger} \text{---} \stackrel{\text{def}}{=} \text{---} \text{---}^{\dagger} \text{---} \stackrel{\text{def}}{=} \text{---} \text{---}^{\dagger} \text{---}$$

For an intuition consider **Rel**: it is easy to check that R^\dagger is just the opposite relation of R .

Lemma 4.2. *If \mathbf{C} is a cartesian bicategory of relations, then $\dagger : \mathbf{C}^{op} \rightarrow \mathbf{C}$ is a 2-functor:*

(i) $\text{id}^\dagger = \text{id}$

(ii) $(R ; S)^\dagger = S^\dagger ; R^\dagger$

(iii) $(R \oplus S)^\dagger = R^\dagger \oplus S^\dagger$

(iv) *If we have*

$$\text{---} \boxed{R} \text{---} \subseteq \text{---} \boxed{S} \text{---},$$

then

$$\text{---} \boxed{R} \text{---} \subseteq \text{---} \boxed{\varnothing} \text{---}.$$

Proof. (i) is easy to check; it is the so-called snake lemma. For (ii):

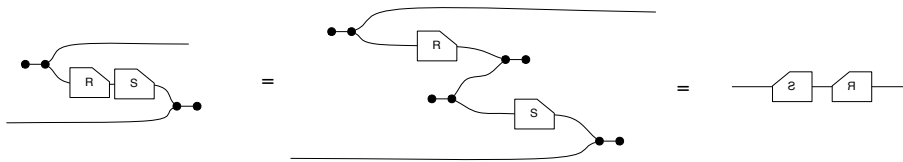

For (iii):

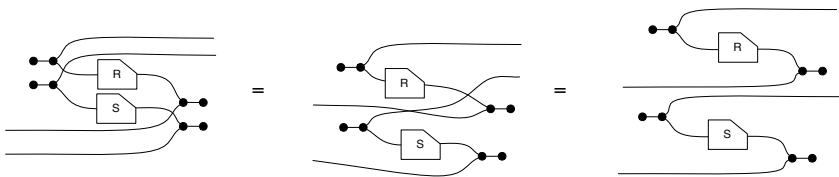

For (iv):

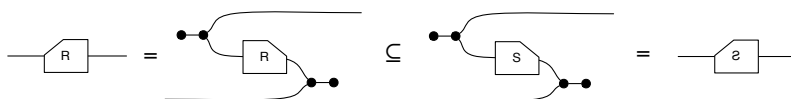

□

Maps and comaps. By applying Lemma 4.2(ii) and (iv) to Inequalities (39) and (40), one obtains the following two inequalities for any arrow $R : m \rightarrow n$ of a cartesian

bicategory of relations:

$$\bullet \text{---} R \text{---} \bullet \leq \bullet \text{---} \bullet \tag{41}$$

$$\begin{array}{c} \text{---} \\ \text{---} \end{array} \bullet \text{---} R \text{---} \bullet \leq \begin{array}{c} \text{---} R \\ \text{---} R \end{array} \bullet \text{---} \bullet \tag{42}$$

The inequations below do *not* in general hold:

$$\begin{array}{c} \text{---} \\ \text{---} \end{array} \bullet \text{---} \begin{array}{c} R \\ R \end{array} \leq \begin{array}{c} R \\ \text{---} \end{array} \bullet \text{---} \begin{array}{c} \text{---} \\ \text{---} \end{array} \tag{SV}$$

$$\bullet \text{---} \bullet \leq \text{---} R \bullet \tag{TOT}$$

$$\begin{array}{c} \text{---} R \\ \text{---} R \end{array} \bullet \text{---} \bullet \leq \begin{array}{c} \text{---} \\ \text{---} \end{array} \bullet \text{---} R \text{---} \bullet \tag{INJ}$$

$$\bullet \text{---} \bullet \leq \bullet \text{---} R \text{---} \bullet \tag{SUR}$$

An arrow $R : m \rightarrow n$ in a cartesian bicategory is said to be *single valued*, *total*, *injective*, or *surjective* if it satisfies (SV), (TOT), (INJ), or (SUR), respectively. A *map* is an arrow that is both single valued and total, namely a comonoid homomorphism. A *comap* is an arrow that is both injective and surjective, namely a monoid homomorphism. It is easy to see that in **Rel**, these coincide with the familiar notions.

The simple lemma below will be useful in subsequent proofs.

Lemma 4.3 (Wrong way). *We have:*

$$\begin{array}{c} \text{---} \\ \text{---} \end{array} \bullet \text{---} \begin{array}{c} \text{---} \\ \text{---} \end{array} \leq \begin{array}{c} \text{---} R \\ \text{---} \end{array} \bullet \text{---} \begin{array}{c} \text{---} R \\ \text{---} \end{array}$$

Proof.

$$\begin{array}{c} \text{---} \\ \text{---} \end{array} \bullet \text{---} \begin{array}{c} \text{---} \\ \text{---} \end{array} = \begin{array}{c} \bullet \\ \bullet \end{array} \begin{array}{c} \text{---} \\ \text{---} \end{array} \bullet \text{---} \begin{array}{c} \text{---} \\ \text{---} \end{array} \leq \begin{array}{c} \bullet \\ \bullet \end{array} \begin{array}{c} \text{---} R \\ \text{---} R \end{array} \bullet \text{---} \bullet = \begin{array}{c} \bullet \\ \bullet \end{array} \begin{array}{c} \text{---} R \\ \text{---} R \end{array} \bullet \text{---} \begin{array}{c} \text{---} R \\ \text{---} R \end{array} \bullet \text{---} \bullet = \begin{array}{c} \text{---} R \\ \text{---} \end{array} \bullet \text{---} \begin{array}{c} \text{---} R \\ \text{---} \end{array}$$

□

Lemma 4.4. Consider the four inequalities:

$$\text{---} \begin{array}{c} \diagup \text{R} \diagdown \\ \diagdown \text{R} \diagup \end{array} \text{---} \leq \text{---} \tag{43}$$

$$\text{---} \leq \text{---} \begin{array}{c} \text{R} \diagdown \\ \text{R} \diagup \end{array} \text{---} \tag{44}$$

$$\text{---} \begin{array}{c} \text{R} \diagdown \\ \text{R} \diagup \end{array} \begin{array}{c} \diagdown \text{R} \diagup \\ \diagup \text{R} \diagdown \end{array} \text{---} \leq \text{---} \tag{45}$$

$$\text{---} \leq \text{---} \begin{array}{c} \text{R} \diagup \\ \text{R} \diagdown \end{array} \text{---} \tag{46}$$

An arrow $R : m \rightarrow n$ is single valued iff (43) holds, total iff (44) holds, injective iff (45) holds and surjective iff (46) holds.

Proof. (SV) \Rightarrow (43):

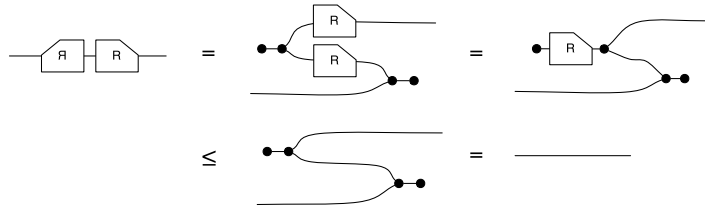

(43) \Rightarrow (SV):

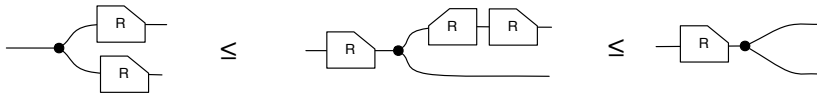

(TOT) \Rightarrow (44):

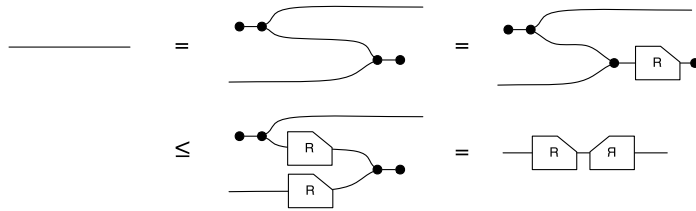

(44) \Rightarrow (TOT):

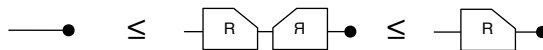

(INJ) \Leftrightarrow (45) follows as a corollary of (SV) \Leftrightarrow (43).

(SUR) \Leftrightarrow (46) follows as a corollary of (TOT) \Leftrightarrow (44).

□

Corollary 4.5. Let $R, S : m \rightarrow n$ be two maps. If $R \leq S$ then $R = S$.

Corollary 4.6 (Span cancellation). An arrow R is single valued and surjective if and only if it satisfies:

$$\text{---} \begin{array}{c} \diagup \\ \text{R} \\ \diagdown \end{array} \begin{array}{c} \diagdown \\ \text{R} \\ \diagup \end{array} \text{---} = \text{---}$$

Corollary 4.7 (Cospan cancellation). An arrow R is injective and total if and only if it satisfies:

$$\text{---} \begin{array}{c} \diagdown \\ \text{R} \\ \diagup \end{array} \begin{array}{c} \diagup \\ \text{R} \\ \diagdown \end{array} \text{---} = \text{---}$$

Lemma 4.8. R is a map if and only if it has a right adjoint. Its right adjoint is then R^\dagger .

Proof. If R is a map, then it is total and single valued. The fact that it is total gives the unit (44) of the adjunction and the fact that it is single valued gives the counit (43).

Suppose that R has right adjoint S :

$$\text{---} \leq \text{---} \begin{array}{c} \diagdown \\ \text{R} \\ \diagup \end{array} \begin{array}{c} \diagup \\ \text{S} \\ \diagdown \end{array} \text{---} \quad \text{---} \begin{array}{c} \diagup \\ \text{S} \\ \diagdown \end{array} \begin{array}{c} \diagdown \\ \text{R} \\ \diagup \end{array} \leq \text{---}$$

Then:

$$\begin{array}{c} \bullet \\ \diagup \\ \text{R} \\ \diagdown \\ \bullet \end{array} \leq \text{---} \begin{array}{c} \diagdown \\ \text{R} \\ \diagup \end{array} \begin{array}{c} \diagup \\ \text{S} \\ \diagdown \end{array} \begin{array}{c} \bullet \\ \diagdown \\ \text{R} \\ \diagup \\ \bullet \end{array} \\ \leq \text{---} \begin{array}{c} \diagdown \\ \text{R} \\ \diagup \end{array} \begin{array}{c} \bullet \\ \diagdown \\ \text{S} \\ \diagup \\ \bullet \end{array} \begin{array}{c} \diagup \\ \text{R} \\ \diagdown \end{array} \leq \text{---} \begin{array}{c} \bullet \\ \diagdown \\ \text{R} \\ \diagup \\ \bullet \end{array}$$

Thus, R is single valued, and

$$\text{---} \bullet \leq \text{---} \begin{array}{c} \diagdown \\ \text{R} \\ \diagup \end{array} \begin{array}{c} \diagup \\ \text{S} \\ \diagdown \end{array} \bullet \leq \text{---} \begin{array}{c} \diagdown \\ \text{R} \\ \diagup \end{array} \bullet$$

so R is total. By Lemma 4.4, R^\dagger is also right adjoint to R . Thus, by the standard argument, we have

$$\text{---} \begin{array}{c} \diagup \\ \text{S} \\ \diagdown \end{array} \text{---} = \text{---} \begin{array}{c} \diagdown \\ \text{R} \\ \diagup \end{array} \text{---}$$

□

Corollary 4.9. An arrow R is a comap if and only if it has a left adjoint S ; in that case, we have $S = R^\dagger$.

Corollary 4.10. An arrow R is an isomorphism if and only if $R^{-1} = R^\dagger$.

Convolution. We now show that in a cartesian bicategory of relations every hom-set is a meet-semilattice. Given arrows $A : m \rightarrow n$ and $B : m \rightarrow n$ we define the *convolution* of A and B , written $A \otimes B$, by:

$$\otimes \stackrel{\text{def}}{=} \Delta_m ; A \oplus B ; \nabla_n = \begin{array}{c} \text{---} \bullet \text{---} \text{---} \bullet \text{---} \\ \text{---} \text{---} \text{---} \text{---} \\ \text{---} \bullet \text{---} \text{---} \bullet \text{---} \\ \text{---} \text{---} \text{---} \text{---} \\ \text{---} \bullet \text{---} \text{---} \bullet \text{---} \end{array}$$

Lemma 4.11. Convolution is associative, commutative, idempotent and unital, with unit:

$$\top_{m,n} \stackrel{\text{def}}{=} !_m ; ?_n = \text{---} \bullet \text{---} \bullet \text{---}$$

Proof. The proof for associativity, commutativity and unitality is trivial using the fact that $(\Delta, !)$ is a commutative comonoid and $(\nabla, ?)$ is a commutative monoid. For idempotency, observe the inequalities:

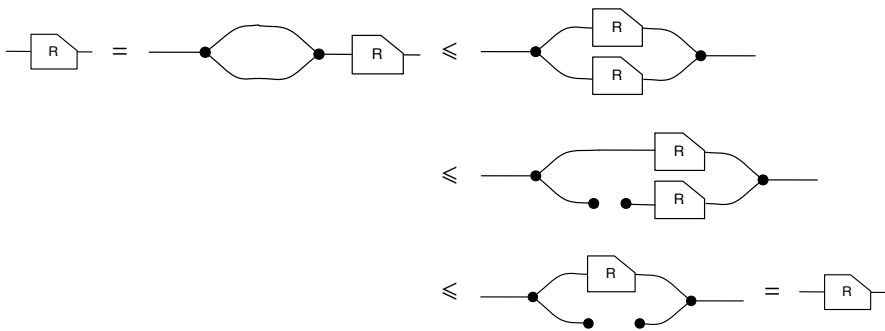

□

Since \otimes is associative, commutative and idempotent, it induces an ordering. In the following we show that this ordering is exactly \leq .

Lemma 4.12. For all arrows $R : n \rightarrow m$, we have $R \leq \top_{m,n}$.

Proof. Consider:



□

Lemma 4.13. $R \otimes S = S$ if and only if $S \leq R$.

Proof. Assume $R \otimes S = S$. Then $R = R \otimes \top \geq R \otimes S = S$. Assume $S \leq R$. Then $R \otimes S \geq S \otimes S = S$. Moreover $S = S \otimes \top \geq S \otimes R$. □

Corollary 4.14. The partial order \leq is a meet-semilattice with top.

4.1 Carboni–Walters categories and Frobenius theories

In ordinary functorial semantics, any finite product category can serve as a semantic domain, with the category of sets and functions the default choice. Cartesian bicategories of relations will serve as the domain for our notion of functorial semantics, with the category of sets and *relations* as a particularly useful universe.

We call an ordered prop that is, additionally, a cartesian bicategory of relations a *prop* (Frobenius prop) or a *Carboni–Walters category*. Similarly to how a cartesian theory results in a Lawvere category, a Frobenius theory results in a Carboni–Walters category. To formally introduce this fact is convenient to consider the SMIT CW: the signature Σ_{CW} consists of $\dashv\!\!\!\dashv : 1 \rightarrow 2$, $\bullet : 1 \rightarrow 0$, $\dashv\!\!\!\dashv : 2 \rightarrow 1$ and $\bullet : 0 \rightarrow 1$. The set I_{CW} contains the inequations for comonoids, monoids and (34)–(38) for $n = 1$. The ordered PROP freely generated by CW is a cartesian bicategory of relations: for every natural number n , the comonoids and monoid are defined analogously to Example 2.5(a). It is then easy to check that the Inequations (34)–(40) hold.

Similarly to how cartesian theories implicitly contain the SMT of comonoids when generating props, Frobenius theories implicitly contain the SMIT CW.

Definition 4.15. A (presentation of a) Frobenius theory (FT) is a pair $\mathbb{T} = (\Sigma, I)$ consisting of a signature Σ and a set of inequations I . The signature Σ is a set of generators $\sigma : n \rightarrow m$ with arity n and coarity m . The set of inequations I contains pairs $(t, t' : n \rightarrow m)$ of Frobenius Σ -terms, namely arrows of the ordered PROP freely generated by the SMIT $(\Sigma \uplus \Sigma_{CW}, I_{CW} \uplus I_{LCH})$ where I_{LCH} is the set containing the Inequations (30) and (31) for each generator $\sigma : m \rightarrow n$ in Σ .

The Carboni–Walters category freely generated by a Frobenius theory $\mathbb{T} = (\Sigma, I)$, denoted by $\mathcal{F}_{\mathbb{T}}$, is the ordered PROP freely generated by the SMIT $(\Sigma \uplus \Sigma_{CW}, I \uplus I_{CW} \uplus I_{LCH})$. The latter will be often referred to as the SMIT corresponding to the Frobenius theory (Σ, I) .

Example 4.16.

- (a) The SMIT of commutative monoids $\mathbb{CM} = (\Sigma_M, E_M \uplus E_M^{op})$ from Example 3.3(a) can be regarded also as a Frobenius theory. In the corresponding SMIT, $(\Sigma_M \uplus \Sigma_{CW}, E_M \uplus E_M^{op} \uplus I_{CW} \uplus I_{LCH})$ one has two monoidal structures which we refer as the *white monoid* (coming from Σ_M) and the *black monoid* (coming from Σ_{CW}). Moreover, since $\mathcal{F}_{\mathbb{CM}}$ is an CW-category, we have also $\dashv\!\!\!\dashv ::= (\dashv\!\!\!\dashv)^\dagger$ and $\bullet ::= (\bullet)^\dagger$. Graphically:

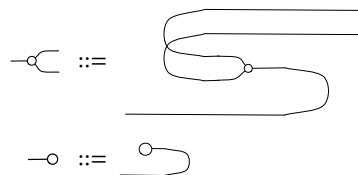

It is easy to prove that $(\dashv\!\!\!\dashv, \bullet)$ forms a cocommutative comonoid. Observe that the set I_{LCH} consists of Inequations (22)–(25) from the theory of lax bialgebras (Example 3.3(d)).

(b) To the previous theory we can add Inequalities (26)–(29) from the theory of oplax bialgebra (Example 3.3(e)). Since in all these equations, the left- and right-hand side are Frobenius terms, the result is a Frobenius theory: we denote it by $\text{CM}^+ = (\Sigma_M, E_M \uplus E_M^{op} \uplus B^{op})$. Since both inequalities hold, the black and white structures form a bialgebra. The corresponding SMIT is illustrated in Figure 2.

In Section 6, we will see that this theory can be understood as the result of a more general construction and that, in a precise sense, it is equivalent to the cartesian theory of monoids (Example 2.7(a)). For this reason, we will refer to this theory as *the Frobenius theory of monoids*. In Section 7, we will show that it provides a rich algebraic playground.

We can define an appropriate category of models for Frobenius theories in a similar way to how it is defined for symmetric monoidal and cartesian theories,

Definition 4.17. *Given a cartesian bicategory of relations \mathbf{C} , a model of a Frobenius theory \mathbb{T} in \mathbf{C} is a cartesian bifunctor $F : \mathcal{F}_{\mathbb{T}} \rightarrow \mathbf{C}$. A morphism of models $F \rightarrow G$ is a lax-natural monoidal transformation $\alpha : F \Rightarrow G$. This means that α is a family of \mathbf{C} -morphisms $\{\alpha_n : Fn \rightarrow Gn\}_{n \in \mathbb{N}}$ such that, for all $f : n \rightarrow m$ in $\mathcal{F}_{\Sigma, E}$, we have*

$$\begin{array}{ccc} Fn & \xrightarrow{\alpha_n} & Gn \\ Ff \downarrow & \llcorner & \downarrow Gf \\ Fm & \xrightarrow{\alpha_m} & Gm \end{array}$$

and $\alpha_{n+m} = \alpha_n \oplus \alpha_m$ with $\alpha_0 = \text{id}_0$.

The category of models of \mathbb{T} in \mathbf{C} and their morphisms is denoted by $\text{Mod}_{\text{FROB}}(\mathbb{T}, \mathbf{C})$.

Since a cartesian bifunctor is obliged to preserve lax products, it is forced to map the Frobenius structure of $\mathcal{F}_{\mathbb{T}}$ into the unique Frobenius structure of \mathbf{C} that determines the lax product. When $\mathbf{C} = \text{Rel}$, this means that any cartesian bifunctor $F : \mathcal{F}_{\mathbb{T}} \rightarrow \text{Rel}$ maps

$$\begin{array}{ll} \text{---} \cup \text{---} \mapsto \{(x, (x, x)) : x \in F1\} & \text{---} \bullet \mapsto \{(x, \bullet) : x \in F1\} \\ \text{---} \cap \text{---} \mapsto \{((x, x), x) : x \in F1\} & \bullet \text{---} \mapsto \{(\bullet, x) : x \in F1\} \end{array}$$

where \bullet is the unique element of the singleton set $\{\bullet\} = 1 = (F1)^0$. Therefore, a model F is determined by the object $F1$ and the arrows Fo for all $o \in \Sigma$. The implications of using lax natural transformations as model homomorphisms are explained in the next section.

5 Examples of Frobenius theories

In this section, we consider some examples of simple Frobenius theories and their models. We usually interpret the theory in the cartesian bicategory of relations Rel .

The theory of sets. We first answer the obvious question: what is the category of models for the empty Frobenius theory (\emptyset, \emptyset) ? The answer is at first sight surprising: this is just **Set** the category of sets and functions. Indeed, a cartesian bifunctor $F : \mathcal{F}_{\emptyset, \emptyset} \rightarrow \mathbf{Rel}$ is uniquely determined by the object $F1$, which is just a set.

A morphism of models $\alpha : F \Rightarrow G$ is determined by $\alpha_1 : F1 \rightarrow G1$ which is a relation satisfying the requirement that the following four squares laxly-commute.

$$\begin{array}{cccc}
 \begin{array}{ccc} F1 & \xrightarrow{\alpha_1} & G1 \\ \Delta \downarrow & \leq & \downarrow \Delta \\ F2 & \xrightarrow{\alpha_1 \oplus \alpha_1} & G2 \end{array} &
 \begin{array}{ccc} F1 & \xrightarrow{\alpha_1} & G1 \\ ! \downarrow & \leq & \downarrow ! \\ F0 & \xrightarrow{\text{id}_0} & G0 \end{array} &
 \begin{array}{ccc} F2 & \xrightarrow{\alpha_1 \oplus \alpha_1} & G1 \\ \nabla \downarrow & \leq & \downarrow \nabla \\ F1 & \xrightarrow{\alpha_1} & G1 \end{array} &
 \begin{array}{ccc} F0 & \xrightarrow{\text{id}_0} & G0 \\ ? \downarrow & \leq & \downarrow ? \\ F1 & \xrightarrow{\alpha_1} & G1 \end{array}
 \end{array}$$

The inequalities in the two rightmost squares hold for any relations. Instead the inclusion in the two leftmost squares holds if and only if the relation is a map, and maps in **Rel** coincide with functions.

Remark 5.1. Requiring morphisms of models to be strict natural transformations rather than just lax (as in Definition 4.17) would mean to force the four above inequalities to be equalities. In this case, a morphism of model would be both a map and a comap, namely an isomorphism.

The theory of non-empty sets. Let us now consider the Frobenius theory having empty signature and the inequation:

$$\text{id}_0 \leq \bullet \text{---} \bullet \tag{47}$$

Observe that the reverse of (47) is (36). Here, therefore, the so-called *bone* equation holds:

$$\bullet \text{---} \bullet = \text{id}_0$$

The corresponding SMIT has been studied in [15, 24, 27, 54]. In these works it is proven that the resulting prop is isomorphic – forgetting the posetal structure – to the prop of equivalence relations (where a morphism $n \rightarrow m$ is an equivalence relation on $n + m$ regarded as a set).

From our perspective, this theory has quite a different meaning. Its models are sets that contain at least one element: indeed any cartesian bifunctor F to **Rel** maps 0 to $(F1)^0$, i.e., the singleton set $\{\bullet\}$, the left-hand side of (47) to $\text{id}_{\{\bullet\}} = \{(\bullet, \bullet)\}$ and the right-hand side to the relational composition of $\{(\bullet, x) : x \in F1\}$ and $\{(x, \bullet) : x \in F1\}$. It follows that (47) holds if and only if $F1$ is not empty.

Morphisms are functions, for the same reasons as in the previous example.

The theory of predicates. We start adding symbols to the signature: consider the theory containing an operation $\circ - : 0 \rightarrow 1$ and no equations. A model for this theory

consists of a set $F1$ and a predicate $F(\circ -) \subseteq F1$. A morphism of models $\alpha : F \Rightarrow G$ is uniquely determined by $\alpha_1 : F1 \rightarrow G1$ which is a function (for the same reason discussed above) which additionally satisfies the inequality:

$$\begin{array}{ccc}
 F0 & \xrightarrow{\text{id}_0} & G0 \\
 \downarrow F(\text{ERROR}) & \subseteq & \downarrow G(\text{ERROR}) \\
 F1 & \xrightarrow{\alpha_1} & G1
 \end{array}$$

To make it more explicit the category of models for this theory is the category of predicates and predicate-preserving functions.

The theory of pointed sets. We can extend the theory of predicates by requiring $\circ -$ to be total and single valued. That is, we impose Inequations (27) and (29). A model for this theory is a set $F1$ with a function $F(\circ -) : F0 \rightarrow F1$. Since $F0$ is the singleton set $\{\bullet\}$, this is a pointed set. A morphism of models is a function preserving the point. In the diagram

$$\begin{array}{ccc}
 F0 & \xrightarrow{\text{id}_0} & G0 \\
 \downarrow F(\text{ERROR}) & \leq & \downarrow G(\text{ERROR}) \\
 F1 & \xrightarrow{\alpha_1} & G1
 \end{array}$$

all arrows are maps and therefore, by Corollary 4.5, they commute strictly not just laxly. Observe that the reverse of Inequations (27) and (29) are equations in the SMIT corresponding to this theory. Therefore we have:

$$\begin{aligned}
 \circ - \bullet &= \text{id}_0 \\
 \begin{array}{c} \circ - \\ \circ - \end{array} &= \begin{array}{c} \circ - \bullet \\ \circ - \end{array}
 \end{aligned}$$

With these equations, we can prove that every pointed set is non-empty, namely that Inequation (47) holds; indeed:

$$\text{id}_0 = \begin{array}{c} \circ - \bullet \\ \circ - \end{array} \stackrel{(31)}{\leq} \bullet - \bullet$$

Another simple graphical derivation proves that $\circ -$ is injective:

$$\begin{array}{c} \circ - \bullet \\ \circ - \end{array} = \begin{array}{c} \circ - \bullet \\ \circ - \bullet \end{array} \stackrel{(34)}{\leq} \begin{array}{c} \circ - \bullet \\ \circ - \end{array} = \circ -$$

Thus, by Corollary 4.7, we have the (white) bone law

$$\circ - \circ = \text{id}_0 \tag{48}$$

where, as in Example 4.16(a), $\circ : 1 \rightarrow 0$ is the notation for $\circ \dashv$.

The last property that we are going to show is:

$$\begin{array}{c}
 \text{Diagram 1} = \text{Diagram 2} \stackrel{(38)}{=} \text{Diagram 3} \\
 = \text{Diagram 4} = \text{Diagram 5}
 \end{array}$$

The diagrams represent string diagrams for the Frobenius theory of pointed sets. Diagram 1 shows a multiplication node (black dot) with a comultiplication node (white dot) below it. Diagram 2 shows a similar structure with a different wiring. Diagram 3 is a more complex wiring. Diagram 4 shows a multiplication node with a comultiplication node below it, but with different connections. Diagram 5 shows two separate comultiplication nodes.

The above equation proves that the Carboni–Walters category generated by the Frobenius theory of pointed sets is isomorphic (disregarding the posetal structure) to the prop of *partial equivalence relations* studied in [54].

The theory of binary relations. We now consider the theory containing an operation $R : 1 \rightarrow 1$ and no equations. A model for this theory consists of a set $F1$ and a relation $FR \subseteq F1 \times F1$. A morphism of models $\alpha : F \Rightarrow G$ is determined by $\alpha_1 : F1 \rightarrow G1$ which is a function that satisfies the inequality:

$$\begin{array}{ccc}
 F0 & \xrightarrow{\alpha_1} & G0 \\
 FR \downarrow & \leq & \downarrow GR \\
 F1 & \xrightarrow{\alpha_1} & G1
 \end{array}$$

This simply means that the function α_1 *preserves* the relation R : if $(x, y) \in FR$, then $(\alpha_1(x), \alpha_1(y)) \in GR$. The category of models is, therefore, the category of binary relations.

The theory of partial orders. The category of partial orders and monotone maps can be obtained as the category of models of a Frobenius theory : the signature consists of a single symbol $\square : 1 \rightarrow 1$ representing a relation and the three inequations below impose reflexivity, transitivity and antisymmetry:

$$\text{Diagram 1} \leq \square \tag{49}$$

$$\square \square \leq \square \tag{50}$$

$$\text{Diagram 2} \leq \text{Diagram 3} \tag{51}$$

Diagram 2 shows two square nodes stacked vertically with curved arrows connecting their top and bottom edges. Diagram 3 is a single horizontal line.

In Inequation (51), $-\square-$: $1 \rightarrow 1$ is the inverse relation of $-\sqsubseteq-$ formally defined as $-\square-$ \dagger . Graphically:

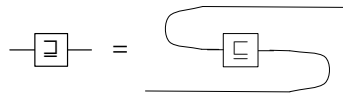

It is easy to see that a model for this theory is exactly a set equipped with a relation that is a partial order. By spelling out the definitions of morphism of model, the same arguments of the previous example applies: a morphism is just a function that preserves the relation, namely a monotone function. The category of models is thus the usual category of posets and monotone functions.

Remark 5.2. Modifying the above, one obtains many familiar theories. For instance, by replacing antisymmetry (Inequation (51)) by symmetry ($-\square- \leq -\square-$) one obtains equivalence relations. By dropping it, one gets pre-orders.

The theory of deterministic automata. A deterministic automaton (DA) on a finite alphabet A consists of a triple (X, t, f) , where X is a set of states, $t : X \rightarrow X^A$ is the transition function and $f \subseteq X$ is its set of final states. Given DAs (X_1, t_1, f_1) and (X_2, t_2, f_2) , a function $h : X_1 \rightarrow X_2$ is a *simulation* if (1) $h(f_1) \subseteq f_2$ and (2), for all $x \in X_1$, and $a \in A$, $h(t_1(x)(a)) = t_2(h(x)(a))$.

We now introduce a Frobenius theory **DA** for deterministic automata and simulations. The signature consists of two symbols $f : 1 \rightarrow 0$ and $t : 1 \rightarrow |A|$. The set of inequations only requires that t is a map: $\Delta ; (t \oplus t) \leq t ; \Delta_{|A|}$ and $! \leq t ; !_{|A|}$.

Then models are exactly deterministic automata. Indeed a model $F : \mathcal{F}_{\text{DA}} \rightarrow \mathbf{Rel}$ consists of a set $F1$ (representing the states) a function $Ft : F1 \rightarrow (F1)^{|A|}$ (the transition) and a relation $Ff : F1 \rightarrow 1 = (F1)^0$, namely a predicate (the final states).

Morphisms are exactly simulations. They are functions for the usual reason and the lax naturality squares

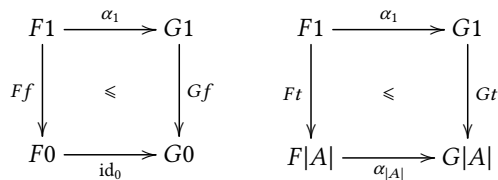

impose, respectively, Conditions (1) and (2) of the definition of simulation.

Remark 5.3. This example suggests that one may use Frobenius theories to express coalgebraic structures. Indeed, one can encode a function $f : X \rightarrow X^n$ either by having in the signature a symbol $f : 1 \rightarrow n$ and imposing the axioms for functions or as a symbol $f : n \rightarrow 1$ and impose the axioms of cofunctions. Then the lax-naturality conditions make the morphism the expected coalgebra homomorphisms.

Unfortunately, one can express only coalgebras for functors of the shapes $F(X) = X^n$, which are usually not particularly interesting: the final coalgebras is always the one

element set 1. More interesting functors, such as $F(X) = X \times X + 1$ (finite and infinite trees), cannot be expressed in our framework: intuitively we are missing the coproduct $+$.

The theory of non-negative monoids. Recall the Frobenius theory of monoids \mathbf{CM}^+ from Example 4.16(b). It is now easy to see that its models in \mathbf{Rel} are simply ordinary monoids in \mathbf{Set} , and morphisms of models are just monoid homomorphisms.

By adding to \mathbf{CM}^+ the inequation

$$\text{Frobenius term with white count} \leq \text{Frobenius term with black count} \tag{52}$$

we obtain the theory of *non-negative monoids*. These are monoids $(X, +, 0)$ with the additional property that, for all $x, y \in X$, if $x + y = 0$, then $x = 0$ and $y = 0$. Note that the string diagrams on both sides of (52) are Frobenius terms: the definition of the white count requires the Frobenius structure.

6 From cartesian theories to Frobenius theories

In Example 2.7(a) we introduced the cartesian theory of commutative monoids \mathbf{CM} . In Example 4.16(b) we showed that the Frobenius theory of commutative monoid \mathbf{CM}^+ is obtained from \mathbf{CM} by adding inequality of oplax bialgebras, that forces the (white) monoid structure to be an oplax (black) comonoid homomorphism. Since in any Frobenius theory, the generators are implicitly forced to be lax comonoid homomorphism (inequations (30) and (31)), one has that in the SMT corresponding to \mathbf{CM}^+ , as in the SMT corresponding to \mathbf{CM} , the white monoid is a *strict* black comonoid homomorphism.

This construction can be generalised as follows: given any cartesian theory $\mathbf{T} = (\Sigma, E)$ one builds the Frobenius theory $\mathbf{T}^+ = (\Sigma, E \uplus E^{op} \uplus I_{OLCH})$ where I_{OLCH} consists of the two inequalities

$$\text{Diagram 1} \leq \text{Diagram 2} \tag{53}$$

$$\text{Diagram 3} \leq \text{Diagram 4} \tag{54}$$

for each generator $\boxed{O}^- : n \rightarrow 1$ in the signature Σ . The two theories are closely related: indeed, the category of cartesian models for \mathbf{T} in \mathbf{Set} is isomorphic to the category of Frobenius models for \mathbf{T}^+ in \mathbf{Rel} .

One can further generalize by replacing \mathbf{Rel} with an arbitrary cartesian bicategory of relations \mathbf{C} and \mathbf{Set} by its *category of maps* $\mathbf{Map}(\mathbf{C})$, which is defined to be the sub-bicategory of \mathbf{C} having as arrows the maps of \mathbf{C} . Indeed, $\mathbf{Map}(\mathbf{C})$ has finite products.

Proposition 6.1 ([18, Theorem 6.1(i)]). *Let \mathbf{C} be a cartesian bicategory of relations. Then $\mathbf{Map}(\mathbf{C})$ is a cartesian category.*

We can now state the main result of this section.

Theorem 6.2. *Let $\mathbb{T} = (\Sigma, E)$ be a cartesian theory and $\mathbb{T}^+ = (\Sigma, E \uplus E^{Op} \uplus I_{OLCH})$. Then $\text{Mod}_{\text{FROB}}(\mathbb{T}^+, \mathbb{C}) \cong \text{Mod}_{\text{CAR}}(\mathbb{T}, \text{Map}(\mathbb{C}))$.*

Proof. This theorem can be proved in several ways. We give a concrete proof that uses the intuitions developed so far for models and their morphisms.

A cartesian bifunctor $F : \mathcal{F}_{\mathbb{T}^+} \rightarrow \mathbb{C}$ is uniquely determined by: (a) the object $F1$ in \mathbb{C} and (b) arrows Fo in \mathbb{C} for any generator $o \in \Sigma$. Inequalities (53) and (54) force each of the Fo to be a map, namely an arrow in $\text{Map}(\mathbb{C})$. The same data uniquely determine a cartesian functor $F : \mathcal{L}_{\mathbb{T}} \rightarrow \text{Map}(\mathbb{C})$.

For morphisms, observe that $\alpha : F \rightarrow G$ of Frobenius models is uniquely determined by an arrow of \mathbb{C} $\alpha_1 : F1 \rightarrow G1$ that is a map (recall from Section 5 the example of the theory of sets). The morphism α is additionally required to be a lax natural transformation, but since all the Fo are maps then, by Corollary 4.5, this just means that α is a (strict) natural transformation. This data uniquely induces a morphism of cartesian models. \square

Thus Frobenius theories are at least as expressive as cartesian theories. The examples of non-empty sets, predicates, binary relations, partial orders, DAs and non-negative monoids in Section 5 show that Frobenius theories are strictly more expressive than classical (cartesian) algebraic theories. In the remainder of this paper, we explore several Frobenius theories arising from well-known cartesian theories.

7 The theory of commutative monoids

In this section we explore the algebraic properties of the Frobenius theory of commutative monoids CM^+ introduced in Example 4.16(b). Its SMIT is illustrated in Figure 2.

Observe that the white monoid and the black comonoid form a *bialgebra* structure (Example 2.3(d)). This has two interesting consequences. First, by Lemma 4.2(iv), we have that also the black monoid and the white comonoid give rise to a bialgebra. Second, we have that both \curvearrowright and \curvearrowleft are total and single valued. By Lemma 4.4, we have the inequalities:

$$\begin{array}{c} \text{---} \\ \text{---} \end{array} \leq \begin{array}{c} \curvearrowright \\ \curvearrowleft \end{array} \quad (55)$$

$$\begin{array}{c} \curvearrowleft \\ \curvearrowright \end{array} \leq \text{---} \quad (56)$$

$$\text{id}_0 \leq \text{---} \quad (57)$$

$$\text{---} \leq \text{---} \quad (58)$$

By using Lemma 4.12, it is easy to see that \curvearrowright is surjective:

$$\begin{array}{c} \bullet \\ \bullet \end{array} \curvearrowright \geq^{(31)} \begin{array}{c} \curvearrowright \\ \bullet \end{array} = \bullet \quad (59)$$

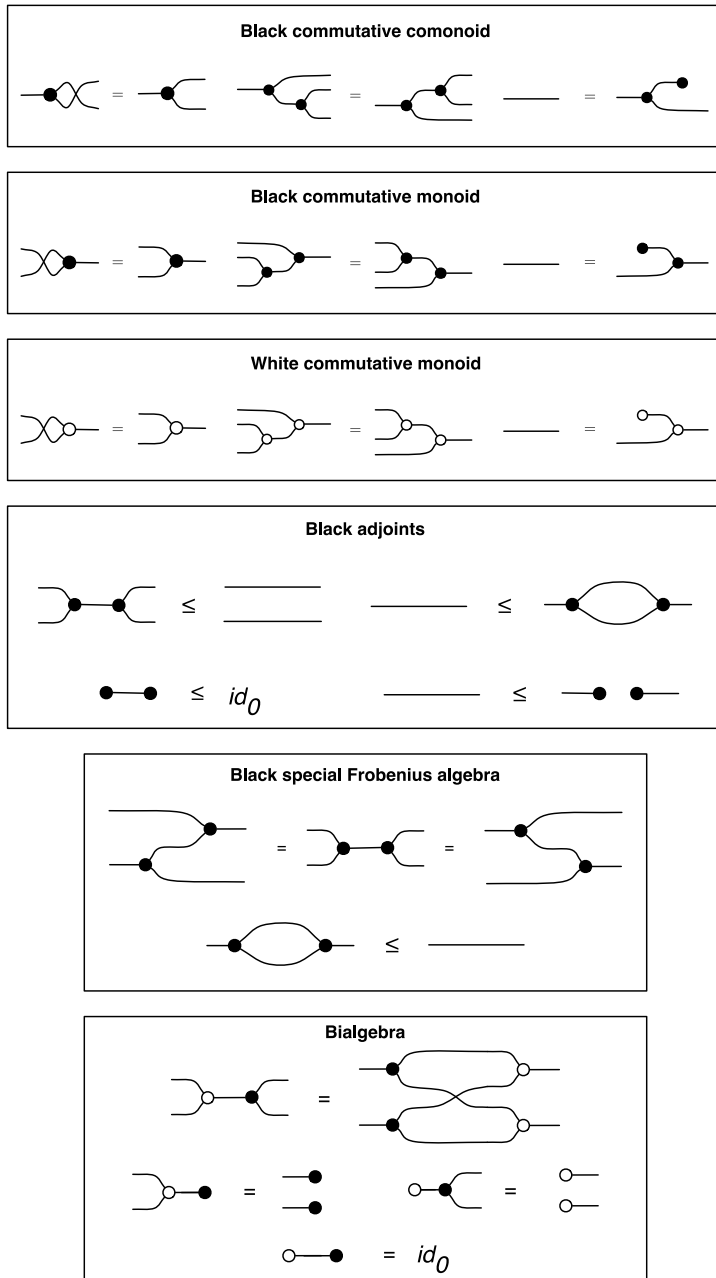

Figure 2: The SMIT corresponding to the Frobenius theory of commutative monoids.

Thus, by Corollary 4.6, we deduce the *white special law*:

$$\text{---} \circ \text{---} = \text{---} \tag{60}$$

As in the theory of pointed sets, $\circ -$ is injective; indeed:

$$\text{---} \circ \bullet = \text{---} \circ \bullet \bullet \bullet \stackrel{(34)}{\leq} \text{---} \circ \bullet = \text{---} \circ - \tag{61}$$

Thus, by Corollary 4.7, we deduce the so-called *white bone law*:

$$\text{---} \circ \text{---} = \text{id}_0$$

Observe that the inverse inclusions for (59) and (61) hold by (41) and (42). Therefore:

$$\begin{aligned} \bullet \bullet \bullet &= \bullet \text{---} \\ \text{---} \circ \bullet &= \text{---} \circ - \end{aligned}$$

These two equations can be weakened to some extent. For the latter, we have:

$$\begin{aligned} \text{---} \circ \bullet &= \text{---} \circ \bullet \bullet \bullet = \text{---} \circ \bullet \bullet \bullet \bullet \bullet \\ &= \text{---} \circ \bullet \bullet \bullet \bullet \bullet = \text{---} \circ \text{---} \circ \text{---} \tag{62} \end{aligned}$$

The “colour-swapped” version below holds only laxly by Lemma 4.12:

$$\bullet \bullet \bullet \leq \text{---} \bullet \bullet \text{---}$$

In any model with carrier X , the other inclusion would mean that for all $x, z \in X$, there exists y such that $x + y = z$. Later we will show that this holds for abelian groups.

Another interesting law which can be derived in the theory of commutative monoids is the *black bone*:

$$\bullet \bullet \bullet = \text{id}_0 \tag{63}$$

Indeed, the left-to-right inequation is just (36). For the right-to-left, observe that:

$$\text{id}_0 = \text{---} \bullet \bullet \stackrel{(31)}{\leq} \bullet \bullet \bullet$$

Recall that (63) does not hold in the theory of sets: the empty set does not satisfy it. Intuitively, (63) states that every commutative monoid has a non-empty carrier set; indeed, it must contain at least the unit element.

The pair of white-monoid white-comonoid forms a *lax Frobenius* structure. This is proved as follows:

$$\begin{array}{c} \text{---} \\ \text{---} \end{array} \circ \begin{array}{c} \text{---} \\ \text{---} \end{array} \stackrel{(55)}{\leq} \begin{array}{c} \text{---} \\ \text{---} \end{array} \circ \begin{array}{c} \text{---} \\ \text{---} \end{array} \circ \begin{array}{c} \text{---} \\ \text{---} \end{array} \stackrel{(7)}{=} \begin{array}{c} \text{---} \\ \text{---} \end{array} \circ \begin{array}{c} \text{---} \\ \text{---} \end{array} \stackrel{(60)}{=} \begin{array}{c} \text{---} \\ \text{---} \end{array} \circ \begin{array}{c} \text{---} \\ \text{---} \end{array} \quad (64)$$

Lemma 4.2(iv) then implies:

$$\begin{array}{c} \text{---} \\ \text{---} \end{array} \circ \begin{array}{c} \text{---} \\ \text{---} \end{array} \leq \begin{array}{c} \text{---} \\ \text{---} \end{array} \circ \begin{array}{c} \text{---} \\ \text{---} \end{array} \quad (65)$$

The pair of white monoid-comonoid forms a *lax bialgebra*. We have seen that (48) holds. The other laws only hold laxly:

$$\begin{array}{c} \text{---} \\ \text{---} \end{array} \circ \begin{array}{c} \text{---} \\ \text{---} \end{array} \stackrel{(55)}{\leq} \begin{array}{c} \text{---} \\ \text{---} \end{array} \circ \begin{array}{c} \text{---} \\ \text{---} \end{array} \stackrel{(9)}{=} \begin{array}{c} \text{---} \\ \text{---} \end{array} \circ \begin{array}{c} \text{---} \\ \text{---} \end{array}$$

Note that the other direction does not hold in general for monoid: it would mean that every monoid is non-negative (see Section 5). The remaining rule can be proved by using the lax Frobenius equations thus:

$$\begin{array}{c} \begin{array}{c} \text{---} \\ \text{---} \end{array} \circ \begin{array}{c} \text{---} \\ \text{---} \end{array} \stackrel{(8)}{=} \begin{array}{c} \text{---} \\ \text{---} \end{array} \circ \begin{array}{c} \text{---} \\ \text{---} \end{array} \stackrel{\text{naturality}}{=} \begin{array}{c} \text{---} \\ \text{---} \end{array} \circ \begin{array}{c} \text{---} \\ \text{---} \end{array} \\ \begin{array}{c} \text{---} \\ \text{---} \end{array} \circ \begin{array}{c} \text{---} \\ \text{---} \end{array} \stackrel{(65)}{\leq} \begin{array}{c} \text{---} \\ \text{---} \end{array} \circ \begin{array}{c} \text{---} \\ \text{---} \end{array} \stackrel{(64)}{\leq} \begin{array}{c} \text{---} \\ \text{---} \end{array} \circ \begin{array}{c} \text{---} \\ \text{---} \end{array} \\ \begin{array}{c} \text{---} \\ \text{---} \end{array} \circ \begin{array}{c} \text{---} \\ \text{---} \end{array} \stackrel{(7)}{=} \begin{array}{c} \text{---} \\ \text{---} \end{array} \circ \begin{array}{c} \text{---} \\ \text{---} \end{array} \stackrel{(8)}{=} \begin{array}{c} \text{---} \\ \text{---} \end{array} \circ \begin{array}{c} \text{---} \\ \text{---} \end{array} \\ \begin{array}{c} \text{---} \\ \text{---} \end{array} \circ \begin{array}{c} \text{---} \\ \text{---} \end{array} \stackrel{(64)}{\leq} \begin{array}{c} \text{---} \\ \text{---} \end{array} \circ \begin{array}{c} \text{---} \\ \text{---} \end{array} \stackrel{(60)}{=} \begin{array}{c} \text{---} \\ \text{---} \end{array} \circ \begin{array}{c} \text{---} \\ \text{---} \end{array} \end{array}$$

Again, the inverse inequation does not hold in general for monoids. We will see in Section 8 that it holds for abelian groups.

The two laws below state that the black multiplication laxly distributes over the white multiplication:

$$\text{Diagram (66)} \leq \text{Diagram (66)} \tag{66}$$

$$\text{Diagram (67)} \leq \text{Diagram (67)} \tag{67}$$

Observe that (66) is an instance of (42), while (67) can be obtained simply by precomposing (66) with a permutation. The inverse inequation does not hold.

Another law, which is useful in several occasions, is

$$\text{Diagram} = \text{Diagram}$$

which can be derived by:

$$\begin{aligned} &\text{Diagram} \stackrel{(38)}{=} \text{Diagram} \stackrel{\text{bialgebra}}{=} \text{Diagram} \\ &\text{Diagram} \stackrel{(38)}{=} \text{Diagram} \stackrel{\text{naturality}}{=} \text{Diagram} \\ &\text{Diagram} \stackrel{\dagger}{=} \text{Diagram} \end{aligned}$$

Additive arrows. We now study general properties of the arrows in $\mathcal{F}_{\text{CM}^+}$. An arrow $R : m \rightarrow n$ is said to be *additive* if it satisfies the two inequations:

$$\text{Diagram (68)} \leq \text{Diagram (68)} \tag{68}$$

$$\text{Diagram (69)} \leq \text{Diagram (69)} \tag{69}$$

In **Rel**, a relation R is additive when it is closed with respect to the structure of a monoid $(X, +, 0)$, that is: (a) if $(x_1, y_1) \in R$ and $(x_2, y_2) \in R$, then $(x_1 + x_2, y_1 + y_2) \in R$ and (b) $(0, 0) \in R$ for all $x_1, x_2, y_1, y_2 \in X$.

An additive arrow is, therefore, an oplax white monoid homomorphism. The fact that it is also an oplax white comonoid homomorphism easily follows from the fact that white multiplication and unit are maps. Indeed:

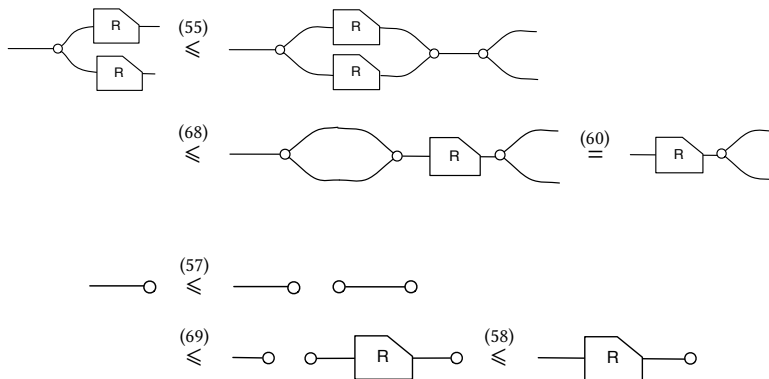

Lemma 7.1. *If R is additive, then R^\dagger is additive.*

Proof. Trivial by using the inequations above. □

Lemma 7.2. *Let R and S be two arrows.*

If R and S are additive then $R ; S$ and $R \oplus S$ are additive.

Proof. Trivial by definition. □

Proposition 7.3. *All arrows in \mathcal{F}_{CM^+} are additive.*

Proof. The proof proceeds by induction on \mathcal{F}_{CM^+} . For the inductive cases, we use Lemma 7.2. For the base cases, we proceed with a case analysis. We show the cases for both \curvearrowright , \circ , \curvearrowleft , \bullet and $\curvearrowright\bullet$, \bullet , \curvearrowleft , \circ . The latter are redundant by Lemma 7.1, but this extended case analysis will turn out to be useful later on.

- For \curvearrowright :

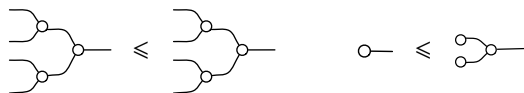

- For \circ :



- For $\text{---}\bullet\text{---}$:

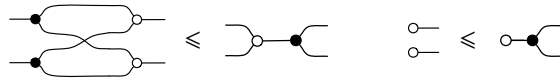

- For $\text{---}\bullet$:



The inequations that we have displayed so far are rather trivial. Those for their opposite are much more interesting.

- For $\text{---}\bullet\text{---}$:

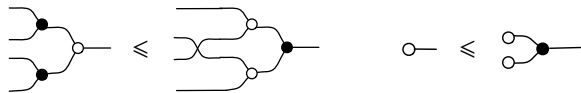

- For $\text{---}\bullet$:

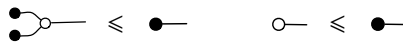

- For $\text{---}\circ\text{---}$:

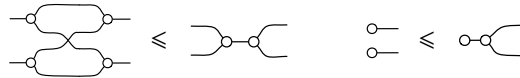

- For $\text{---}\circ$:

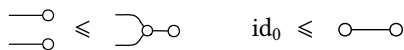

□

Remark 7.4. The second sets of inequations in the above proof contains several of those that we have proved in the main text of this section, e.g., the lax bialgebra for the white structure. Observe that these follow from Lemma 7.1 and the first sets of inequations. This is a more efficient and more structured way to prove those laws. We decided to keep the direct derivations for the sake of exposition.

White convolution. Previously we showed that in any cartesian bicategory of relations, every hom-set carries a meet-semilattice structure. In \mathcal{F}_{CM}^+ this is actually a lattice. Given arrows $R : m \rightarrow n$ and $S : m \rightarrow n$ we define the *white convolution* of R and S , written $R \circledast S$, by:

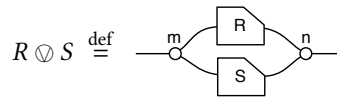

Lemma 7.5. Convolution is associative, commutative, idempotent and unital. Its unit is:

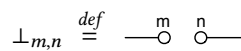

Proof. The proof for associativity, commutativity and unitality is trivial. For idempotency, we use Proposition 7.3:

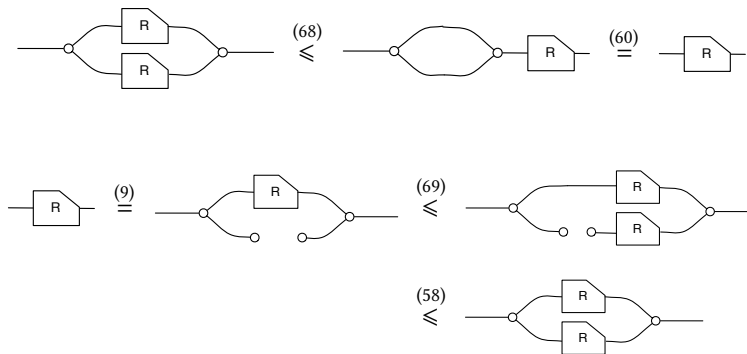

□

Since \circledast is associative, commutative and idempotent, it induces an ordering. In the following, we show that this ordering is exactly \leq .

Lemma 7.6. For all arrows $R : n \rightarrow m$, we have $\perp_{m,n} \leq R$.

Proof.

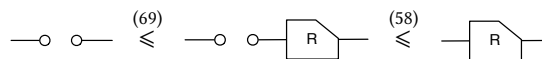

□

Lemma 7.7. $R \circledast S = R$ if and only if $S \leq R$.

Proof. Assume $R \circledast S = R$. Then $S = \perp \circledast S \leq R \circledast S = R$. Assume $S \leq R$. Then $R \circledast S \leq R \circledast R = R$. Moreover $R = R \circledast \perp \leq R \circledast S$. □

Corollary 7.8. *The partial order \leq is a lattice with top and bottom.*

The following fact holds in any lattice.

Lemma 7.9. $R \otimes (S \otimes T) \geq (R \otimes S) \otimes (R \otimes T)$ and $R \otimes (S \oplus T) \leq (R \otimes S) \oplus (R \otimes T)$.

Two other useful properties are displayed below.

Lemma 7.10. $(R \otimes S) ; T \geq (R ; T) \otimes (S ; T)$ and $T ; (R \otimes S) \geq (T ; R) \otimes (T ; S)$.

Proof. It follows immediately from the fact that R , S and T are additive. □

Lemma 7.11. $(R \otimes S)^\dagger = R^\dagger \otimes S^\dagger$.

Proof. Trivial by definition. □

Involution. For every arrow R , we define R° as the arrow that is obtained by switching white and black coloring. To be more formal $(-)^{\circ} : \mathcal{F}_{\text{CM}^+} \rightarrow \mathcal{F}_{\text{CM}^+}$ is the unique symmetric monoidal functor switching black and white colouring. This can be defined inductively: $(R ; S)^{\circ} = R^{\circ} ; S^{\circ}$ and $(R \oplus S)^{\circ} = R^{\circ} \oplus S^{\circ}$ and for the base cases it is just the switching of colours, e.g., $(\text{---}\curvearrowright)^{\circ} = \text{---}\curvearrowleft$.

Lemma 7.12. *The functor $(-)^{\circ}$ is involutive: $(R^{\circ})^{\circ} = R$.*

Proof. Trivial by definition. □

Lemma 7.13. $(R \otimes S)^{\circ} = R^{\circ} \otimes S^{\circ}$ and $(R \oplus S)^{\circ} = R^{\circ} \oplus S^{\circ}$

Proof. Trivial by definition. □

Observe that $(-)^{\circ}$ does not preserve the posetal structure. Indeed, it is not true in general that $R \leq S$ entails that $S^{\circ} \leq R^{\circ}$. Take for instance the black Frobenius equation: we know that the white Frobenius only holds laxly. We will see in Section 8 that the involution operator satisfies this property in the context of abelian groups.

The algebra of additive relations. Our set of operations

$$\top, \perp, \otimes, \oplus, (-)^{\dagger}, (-)^{\circ}, ;, \text{id}$$

is similar to the algebra of relations [34]: full relation, empty relation, intersection, union, inverse, complement, composition and identity relation. While the allegorical fragment [29] (given by the black structure)

$$\top, \otimes, (-)^{\dagger}, ;, \text{id}$$

coincides exactly with the one in the algebra of relations, the remaining part

$$\perp, \oplus, (-)^{\circ}$$

is not exactly the same: \perp is not the empty relation and \oplus is not the union.

We believe that the connection with relational algebra is worth exploring further.

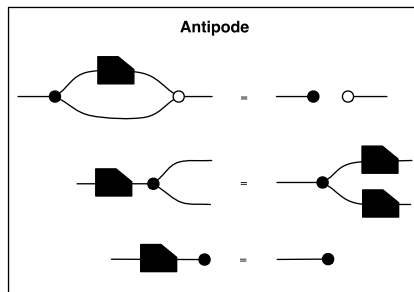

Figure 3: The SMIT corresponding to the Frobenius theory of abelian groups is exactly that of Figure 2 together with the above axioms.

8 The theory of abelian groups

Recall the cartesian theory of abelian groups AG (Example 4.16(b)). In this section we study the Frobenius theory AG^+ obtained by adding to AG Inequalities (26)–(29) of Example 3.3(e) (oplax bialgebras) and the following two inequalities stating that the antipode is a map (single valued and total):

$$\text{---} \bullet \begin{matrix} \nearrow \blacksquare \\ \searrow \blacksquare \end{matrix} \leq \blacksquare \text{---} \bullet \begin{matrix} \nearrow \\ \searrow \end{matrix} \tag{70}$$

$$\text{---} \bullet \leq \blacksquare \text{---} \bullet \tag{71}$$

The corresponding SMIT is shown in Figure 3. As usual, we adopt the graphical convention:

$$\text{---} \blacksquare \text{---} ::= (\text{---} \blacksquare \text{---})^\dagger$$

One may demonstrate that the antipode is its own inverse by the derivation

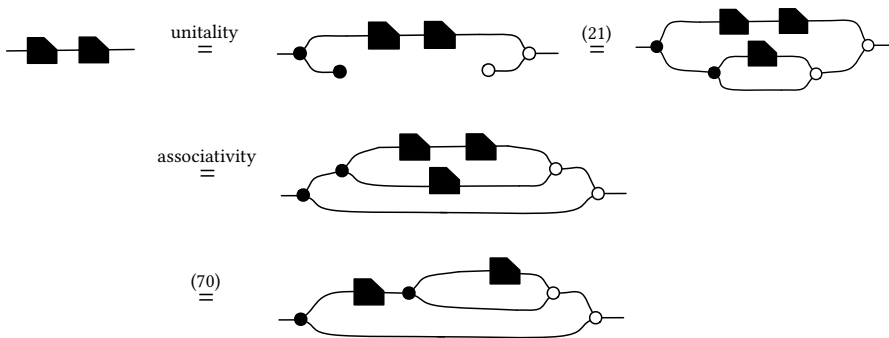

$$\begin{array}{c}
 \stackrel{(21)}{=} \\
 \text{unitality} \\
 \stackrel{=}{=}
 \end{array}
 \begin{array}{c}
 \text{Diagram 1} \\
 \hline
 \text{Diagram 2}
 \end{array}
 \stackrel{(71)}{=}
 \begin{array}{c}
 \text{Diagram 3}
 \end{array}
 \tag{72}$$

which immediately implies that the antipode is injective and surjective and, by Corollary 4.9, that $\text{---}\blacksquare\text{---} = \text{---}\blacksquare\text{---}$. This fact justifies adopting the graphical notation:

$$\text{---}\blacksquare\text{---} ::= \text{---}\blacksquare\text{---} = \text{---}\blacksquare\text{---}$$

We now investigate how the antipode interacts with the white monoid. The following derivation shows that it distributes over the white unit:

$$\begin{array}{c}
 \text{Diagram 1} \\
 \stackrel{(18)}{=} \\
 \text{Diagram 2} \\
 \stackrel{(21)}{=} \\
 \text{Diagram 3} \\
 \stackrel{(16)}{=} \\
 \text{Diagram 4} \\
 \stackrel{(9)}{=} \\
 \text{Diagram 5}
 \end{array}
 \tag{73}$$

The same happens for the white multiplication. To show this, recall the ‘‘De Morgan’’ property:

$$\begin{array}{c}
 \text{Diagram 1} \\
 = \\
 \text{Diagram 2}
 \end{array}
 \tag{74}$$

First, we prove (74):

$$\begin{array}{c}
 \text{Diagram 1} \\
 \stackrel{(70)}{\leq} \\
 \text{Diagram 2} \\
 \stackrel{(72)}{=} \\
 \text{Diagram 3} \\
 \stackrel{(72)}{=} \\
 \text{Diagram 4} \\
 \stackrel{(70)}{\leq} \\
 \text{Diagram 5}
 \end{array}$$

Now, it follows that:

$$\begin{array}{c}
 \text{Diagram 1} \\
 \stackrel{(74)}{=} \\
 \text{Diagram 2} \\
 \stackrel{(72)}{=} \\
 \text{Diagram 3}
 \end{array}
 \tag{75}$$

In other words, the antipode is additive.

A useful ‘‘quasi-Frobenius’’ interaction between the white and black structures is:

$$\begin{array}{c}
 \text{Diagram 1} \\
 = \\
 \text{Diagram 2}
 \end{array}
 \tag{76}$$

To see this, let:

$$\begin{array}{c}
 \text{Diagram 1} \\
 ::= \\
 \text{Diagram 2}
 \end{array}
 \quad
 \begin{array}{c}
 \text{Diagram 3} \\
 ::= \\
 \text{Diagram 4}
 \end{array}$$

Now it is easy to show that $A ; B = B ; A = \text{id}_2$. By the conclusion of Lemma 4.8, it follows that

$$\begin{array}{c} \text{---} \\ \diagup \quad \diagdown \\ \text{A} \\ \diagdown \quad \diagup \\ \text{---} \end{array} = \begin{array}{c} \text{---} \\ \diagdown \quad \diagup \\ \text{B} \\ \diagup \quad \diagdown \\ \text{---} \end{array}$$

which is just (76).

Another important law is

$$\begin{array}{c} \bullet \bullet \\ \diagdown \quad \diagup \\ \text{---} \end{array} = \begin{array}{c} \circ \circ \\ \diagup \quad \diagdown \\ \text{---} \end{array} \quad (77)$$

which follows from (76) by:

$$\begin{array}{c} \circ \circ \\ \diagup \quad \diagdown \\ \text{---} \end{array} \stackrel{\text{Frobenius}}{=} \begin{array}{c} \circ \circ \\ \diagup \quad \diagdown \\ \bullet \bullet \end{array} \stackrel{(76)}{=} \begin{array}{c} \circ \circ \\ \diagdown \quad \diagup \\ \bullet \bullet \end{array} \stackrel{\text{unitality}}{=} \begin{array}{c} \bullet \bullet \\ \diagdown \quad \diagup \\ \text{---} \end{array}$$

Proposition 8.1. *White monoid and comonoid form a Frobenius structure.*

Proof. Since the black structure is Frobenius, it suffices to show:

$$\begin{array}{c} \begin{array}{c} \text{---} \\ \diagdown \quad \diagup \\ \bullet \bullet \end{array} \stackrel{(76)}{=} \begin{array}{c} \bullet \bullet \\ \diagdown \quad \diagup \\ \text{---} \end{array} \stackrel{\text{unitality}}{=} \begin{array}{c} \text{---} \\ \diagdown \quad \diagup \\ \circ \circ \end{array} \\ \\ \begin{array}{c} \text{---} \\ \diagdown \quad \diagup \\ \bullet \bullet \end{array} \stackrel{\text{associativity}}{=} \begin{array}{c} \text{---} \\ \diagdown \quad \diagup \\ \circ \circ \end{array} \stackrel{\text{unitality}}{=} \begin{array}{c} \bullet \bullet \\ \diagdown \quad \diagup \\ \text{---} \end{array} \\ \\ \begin{array}{c} \text{---} \\ \diagdown \quad \diagup \\ \bullet \bullet \end{array} \stackrel{(76)}{=} \begin{array}{c} \bullet \bullet \\ \diagdown \quad \diagup \\ \text{---} \end{array} \end{array}$$

□

An alternative presentation. Thanks to Proposition 8.1, it is easy to see that all the (in)equations in Figure 4 hold in \mathcal{F}_{AG^+} . Actually, one can prove that the ordered PROP freely generated by the SMIT in Figure 4 is isomorphic to \mathcal{F}_{AG^+} : it is enough to define the antipode as either of the following (equivalent) terms

$$\begin{array}{c} \text{---} \\ \diagdown \quad \diagup \\ \bullet \bullet \end{array} = \begin{array}{c} \circ \circ \\ \diagup \quad \diagdown \\ \text{---} \end{array}$$

and check that the (in)equations in Figure 3 are entailed by those in Figure 4. From the isomorphism, it follows that \mathcal{F}_{AG^+} is an *abelian bicategory* [18].

Involution. Involution on \mathcal{F}_{CM^+} can be easily extended to \mathcal{F}_{AG^+} by defining

$$(-\blacksquare-)^{\circ} ::= -\blacksquare-.$$

Now, the fact that white monoid and white comonoid form a special Frobenius algebra gives us the following important proposition.

Proposition 8.2. $R \leq S$ if and only if $R^{\circ} \geq S^{\circ}$.

Proof. It is enough to check that, for each of the inequation $R \leq S$ in the axiomatization in Figure 3, $R^{\circ} \leq S^{\circ}$ holds. \square

The above proposition can be used as an effective proof technique. For instance, to prove that

$$\text{[Diagram: A wire with a dot and a loop] = [Diagram: Two dots on a wire]}$$

it is enough to recall Equation (62) and apply Proposition 8.2.

Since the antipode is a homomorphism of the white monoid (see (73) and (75)), it is an additive arrow. By induction and Lemma 7.2, one can easily prove that all the morphisms in \mathcal{F}_{AG^+} are additive. As a consequence, all the results about \heartsuit , \perp , \otimes , \top , and $(-)^{\circ}$ proved for commutative monoids, still hold for abelian groups. Observe that these operators do *not* form a Boolean algebra as \heartsuit and \otimes distribute over each other only laxly. Other axioms of Boolean algebras that fail are $R \otimes R^{\circ} = \perp$ and $R \heartsuit R^{\circ} = \top$: to see this, it is enough to take $R = \text{id}$.

Antipodal arrows. Since the white structure forms a special Frobenius algebra, it induces a compact closed structure and a contravariant monoidal 2-functor $(-)^{\ddagger}$ mapping every arrow R to

$$R^{\ddagger} ::= \text{[Diagram: A box labeled R with wires forming a loop structure]}$$

In order to prove $R^{\ddagger} = R^{\dagger}$, we will show that it is sufficient for R to be *antipodal*, that is

$$\text{[Diagram: Box R with dot on left]} \leq \text{[Diagram: Box R with dot on right]}$$

which entails

$$\text{[Diagram: Box R with dot on left]} = \text{[Diagram: Box R with dot on right]}$$

So R is antipodal if and only if it is an homomorphism with respect to the antipode.

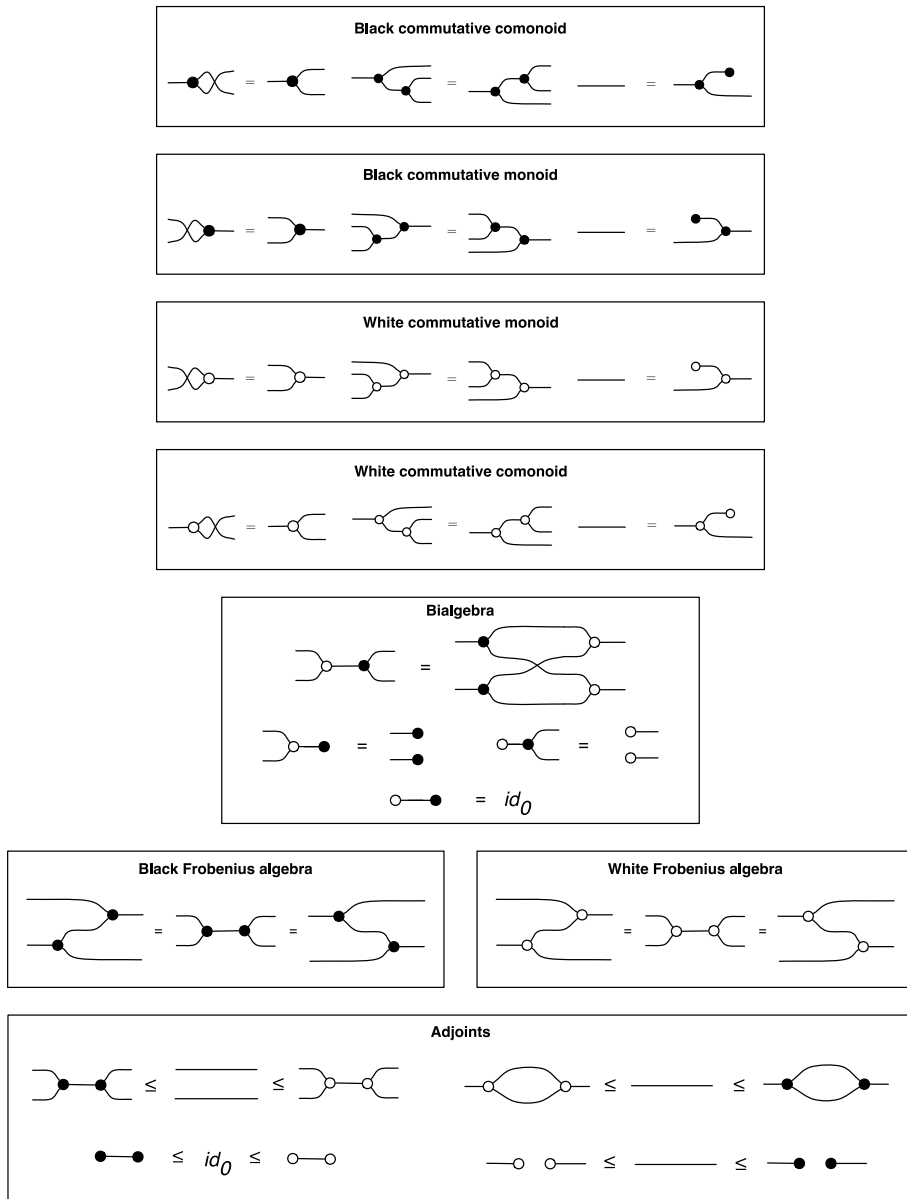
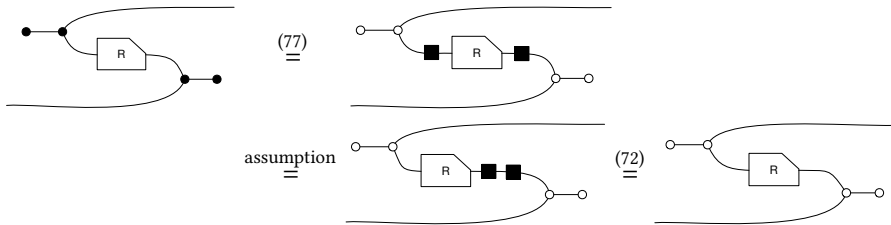

Figure 4: An alternative presentation for the SMIT of abelian groups.

Proposition 8.3. *If R is antipodal, then $R^\dagger = R^\ddagger$.*

Proof.



□

Proposition 8.4. *If R is additive and antipodal, then the following hold:*

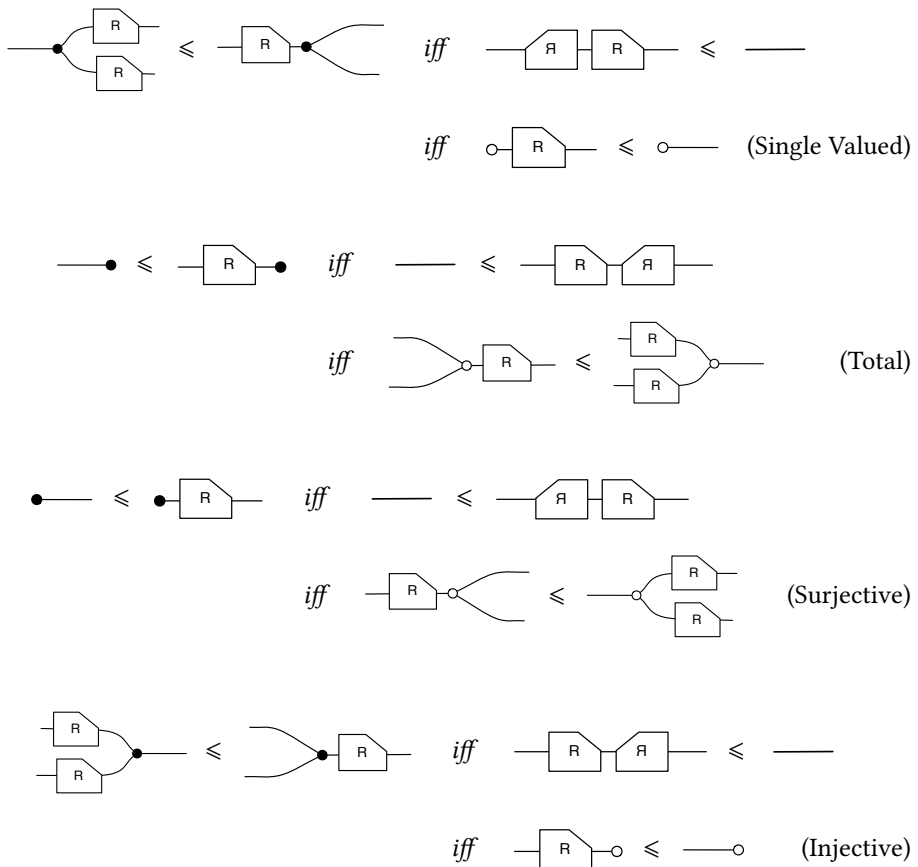

Proof. Since R is antipodal, by Proposition 8.3, $R^\dagger = R^\ddagger$: we can refer to the black and white compact closed structure as the same thing.

The axioms of cartesian bicategories imply that R is a *lax black* comonoid and lax monoid homomorphism. This fact, together with the black Frobenius structure was used in Lemma 4.4 to establish the *iff* between the first two columns in the four rows above.

Since R is additive and has zero, it is a *oplax white* monoid (by definition) and an oplax white comonoid homomorphism (Lemma 7.1).

To prove the *iff* between the third and the second column, it is enough to repeat exactly the same proofs of Lemma 4.4 by exchanging colours and the direction of \leq and \geq . For instance, the *iff* between the second and the third column in (Single Valued) can be retrieved by the *iff* between the second and the first column in (Surjective). \square

Proposition 8.5. *All arrows in \mathcal{F}_{AG^+} are additive and antipodal.*

Proof. By induction. The cases are given by Lemma 7.2, and can be easily extended to take into account antipodality. For the base cases, one can just use those of Proposition 7.3 and observe that every operation of the theory is an antipode homomorphism. \square

Cancellation. We conclude this section by introducing the cancellation proof technique that will be useful for proving properties about modules in the next section.

Proposition 8.6. *Let R and S be arrows in \mathcal{F}_{AG^+} and X be a map. If*

$$\begin{array}{c} \text{---} \bullet \text{---} \\ \diagup \quad \diagdown \\ \boxed{R} \quad \boxed{X} \\ \diagdown \quad \diagup \\ \text{---} \circ \text{---} \end{array} = \begin{array}{c} \text{---} \bullet \text{---} \\ \diagup \quad \diagdown \\ \boxed{S} \quad \boxed{X} \\ \diagdown \quad \diagup \\ \text{---} \circ \text{---} \end{array}$$

then

$$\boxed{R} = \boxed{S} .$$

Proof.

$$\begin{array}{l} \boxed{R} \stackrel{\text{unitality}}{=} \begin{array}{c} \text{---} \bullet \text{---} \\ \diagup \quad \diagdown \\ \boxed{R} \\ \diagdown \quad \diagup \\ \text{---} \circ \text{---} \end{array} \stackrel{X \text{ is total}}{=} \begin{array}{c} \text{---} \bullet \text{---} \\ \diagup \quad \diagdown \\ \boxed{R} \\ \diagdown \quad \diagup \\ \text{---} \bullet \text{---} \end{array} \\ \stackrel{(21)}{=} \begin{array}{c} \text{---} \bullet \text{---} \\ \diagup \quad \diagdown \\ \boxed{R} \\ \diagdown \quad \diagup \\ \text{---} \bullet \text{---} \end{array} \stackrel{\text{associativity}}{=} \begin{array}{c} \text{---} \bullet \text{---} \\ \diagup \quad \diagdown \\ \boxed{R} \\ \diagdown \quad \diagup \\ \text{---} \bullet \text{---} \end{array} \\ \stackrel{\text{assumption}}{=} \begin{array}{c} \text{---} \bullet \text{---} \\ \diagup \quad \diagdown \\ \boxed{S} \\ \diagdown \quad \diagup \\ \text{---} \bullet \text{---} \end{array} = \dots = \boxed{S} . \end{array}$$

\square

9 The theory of R-modules

Let R be a ring. In order to avoid the distinction between left and right modules, we assume R to be commutative. We now illustrate the Frobenius theory of modules over R .

All we have to do is to follow the standard recipe of extending the theory of abelian groups with a scalar operator $\boxed{k} : 1 \rightarrow 1$ for each $k \in R$, impose the usual four axioms for modules and, additionally, require that scalars are maps. The inequations (of the corresponding SMIT) are summarised in Figure 5. We call the underlying Frobenius theory MOD_R^+ and the freely generated Carboni–Walters category $\mathcal{F}_{\text{MOD}_R^+}$.

At first, we observe that the following two important equalities hold:

$$\begin{aligned} \boxed{0} &= \bullet \circ \\ \boxed{-1} &= \blacksquare \end{aligned}$$

They can be proved by using Proposition 8.6 and the two derivations:

$$\begin{aligned} \text{Diagram 1} &= \text{Diagram 2} = \boxed{1} = \text{Diagram 3} = \text{Diagram 4} \\ \text{Diagram 5} &= \boxed{0} = \text{Diagram 6} = \text{Diagram 7} = \text{Diagram 8} \end{aligned}$$

These two simple facts entail that the Carboni–Walters category for the theory of abelian groups is isomorphic to the one for the theory of modules over the ring of integers \mathbb{Z} .

Theorem 9.1. $\mathcal{F}_{\text{AG}} \cong \mathcal{F}_{\text{MOD}_{\mathbb{Z}}^+}$.

Observe that every scalar is – by the (in)equations in Figure 5 – total and single valued. Usually, they are not injective and surjective. However if R is a *field*, every *non-zero* scalar k is both injective and surjective:

$$\boxed{k} \boxed{1/k} = \text{line} = \boxed{1/k} \boxed{k} \tag{78}$$

By Corollary 4.9, this means that:

$$\boxed{k} = \boxed{1/k} \tag{79}$$

This is what happens in the category IH_R of *Interacting Hopf algebras* over R [13].

Theorem 9.2. *If R is a field, then $\text{IH}_R \cong \mathcal{F}_{\text{MOD}_R^+}$.*

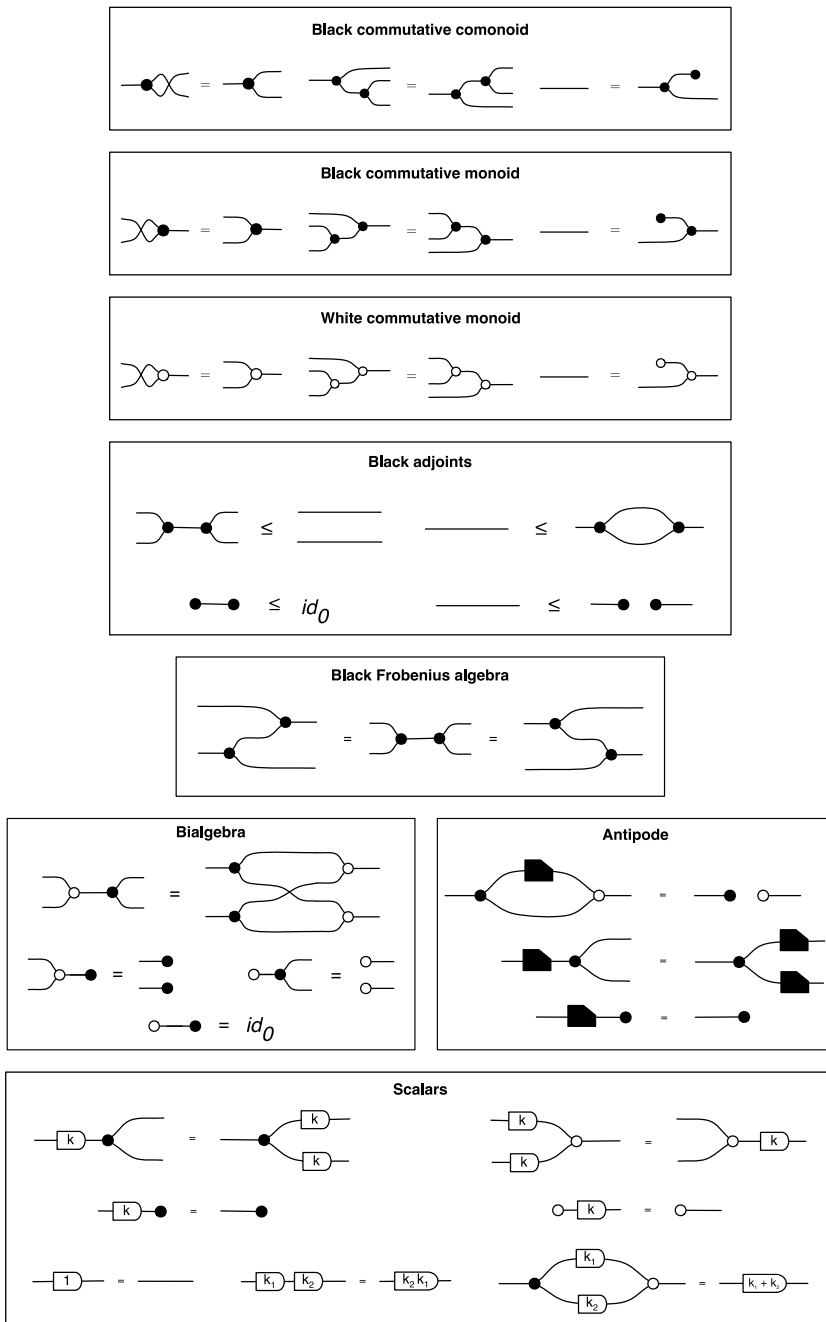

Figure 5: The SMIT corresponding to the Frobenius theory of R-Modules.

Proof. It is enough to check that all the equations in Figure 5 entails those in axioms of \mathbf{IH}_R and vice-versa. \square

Since modules over a field are just vector spaces, we obtain a surprising result.

Corollary 9.3. *If R is a field, then $\text{Mod}_{\text{FROB}}(\mathbf{IH}_R, \text{Rel})$ is the category of vector spaces and linear maps over R .*

We conclude our work with an observation.

Field of fractions. Now we assume R to be an ideal domain. Note that this is not necessarily *principal* as required in [13].

Since R is an ideal domain, we can build its field of fractions $\text{FR}(R)$: elements are pairs p/q of elements of R with $q \neq 0$ quotiented by the equivalence \equiv defined as $p_1/q_1 \equiv p_2/q_2$ if and only if $p_1 \times q_2 = p_2 \times q_1$. Sum and multiplication are defined as $p_1/q_1 + p_2/q_2 = p_1 \times q_2 + p_2 \times q_1 / q_1 \times q_2$ and $p_1/q_1 \times p_2/q_2 = p_1 \times p_2 / q_1 \times q_2$. In the following, we will often use the morphism of rings $(-)/1 : R \rightarrow \text{FR}(R)$ mapping any $k \in R$ into $k/1$.

We now show that the theory of modules over $\text{FR}(R)$ can be retrieved by the one of modules over R by additionally requiring that every non-zero scalar is both injective and surjective. To be entirely formal, we call MODIS_R the theory MOD_R^+ extended with the inequations

$$-\boxed{l} \circ \boxed{l} - \leq \text{---} \leq -\boxed{l} \oplus \boxed{l} - \tag{80}$$

for each scalar $l \in R$ different than 0.

Theorem 9.4. *Let R be an ideal domain. Then $\mathcal{F}_{\text{MOD}_{\text{FR}(R)}^+} \cong \mathcal{F}_{\text{MODIS}_R}$.*

Proof. As a first step, we define a cartesian bifunctor $\iota : \mathcal{F}_{\text{MODIS}_R} \rightarrow \mathcal{F}_{\text{MOD}_{\text{FR}(R)}^+}$ by induction. The inductive cases are given by the fact that it should preserve $;$ and \oplus . For the base cases, ι maps the scalars along $(-)/1 : R \rightarrow \text{FR}(R)$ and for all the others, it behaves as the identity.

To prove that this is well-defined, we check that, for all $R, S \in \mathcal{F}_{\text{MODIS}_R}$,

$$\text{if } R \leq S, \text{ then } \iota(R) \leq \iota(S). \tag{\alpha}$$

To prove this, it is enough to check that (α) holds for each of the inequation of MODIS_R . For inequations that do not involve scalars, (α) is trivial. For the axioms that do involve scalars, we have two cases:

- (a) If $R \leq S$ is an axiom in (80), then it holds in $\mathcal{F}_{\text{MOD}_{\text{FR}(R)}^+}$ by (78) since $\text{FR}(R)$ is a field.
- (b) If $R \leq S$ is an axiom in Figure 5, then it holds since $(-)/1 : R \rightarrow \text{FR}(R)$ is a morphism of rings.

The next step is to define $\kappa : \mathcal{F}_{\text{MOD}_{\text{FR}(\text{R})}^+} \rightarrow \mathcal{F}_{\text{MODIS}_{\text{R}}}$ by induction. Again the inductive cases are fixed. For the base cases, κ maps each scalar $p/q \in \text{FR}(\text{R})$ into

$$\boxed{p} \circ \boxed{q}$$

and, for all the others, it behaves as the identity. Observe that \equiv is preserved by κ : if $p_1/q_1 \equiv p_2/q_2$, then $p_1q_2 = p_2q_1$ and therefore

$$\begin{aligned} \boxed{p_1} \circ \boxed{q_1} &= \boxed{p_1} \circ \boxed{q_2} \circ \boxed{q_2} \circ \boxed{q_1} = \boxed{p_2} \circ \boxed{q_1} \circ \boxed{q_2} \circ \boxed{q_1} \\ &= \boxed{p_2} \circ \boxed{q_1} \circ \boxed{q_1} \circ \boxed{q_2} = \boxed{p_2} \circ \boxed{q_2} . \end{aligned}$$

Again, to prove that κ is well defined, it is enough to inspect the axioms concerning the scalars in Figure 5. For a scalar $p/q \in \text{FR}(\text{R})$, the first axioms of the first and second rows hold in $\mathcal{F}_{\text{MODIS}_{\text{R}}}$, since $q \neq 0$ and (80) entails that \boxed{q} is a black comonoid homomorphism. For the same reason, \boxed{q} is also a white monoid homomorphism and thus it is easy to see that also the second axiom of the second row also holds in $\mathcal{F}_{\text{MODIS}_{\text{R}}}$. The remaining axioms are easily proved using the definition of sum and multiplication in $\text{FR}(\text{R})$.

To conclude it is enough to prove that $\iota \circ \kappa = \text{id}$ and $\kappa \circ \iota = \text{id}$. For both, the proof proceeds by induction. The only interesting cases are the scalars: for $\kappa \circ \iota = \text{id}$, the proof is straightforward; for $\iota \circ \kappa = \text{id}$, the proof uses that (79) holds in $\mathcal{F}_{\text{MOD}_{\text{FR}(\text{R})}^+}$. \square

References

- [1] Samson Abramsky and Bob Coecke. Categorical quantum mechanics. In *Handbook of Quantum Logic and Quantum Structures*, pages 261–323. Elsevier, 2009. DOI: 10.1016/B978-0-444-52869-8.50010-4.
- [2] John C. Baez and Jason Erbele. Categories in control. *Theory and Applications of Categories*, 30(24):836–881, 2015.
- [3] Guillaume Boisseau and Paweł Sobociński. String diagrammatic electrical circuit theory. In *Proceedings of the Fourth International Conference on Applied Category Theory*, volume 372 of *Electronic Proceedings in Theoretical Computer Science*, pages 178–191. Open Publishing Association, 2022. DOI: 10.4204/EPTCS.372.13.
- [4] Filippo Bonchi, Alessandro Di Giorgio, Nathan Haydon, and Paweł Sobociński. Diagrammatic algebra of first order logic. In *Proceedings of the 39th Annual ACM/IEEE Symposium on Logic in Computer Science*, pages 16:1–15. Association for Computing Machinery, 2024. DOI: 10.1145/3661814.3662078.
- [5] Filippo Bonchi, Alessandro Di Giorgio, and Alessio Santamaria. Deconstructing the calculus of relations with tape diagrams. *Proceedings of the ACM on Programming Languages*, 7(POPL):64:1864–1894, 2023. DOI: 10.1145/3571257.

- [6] Filippo Bonchi, Alessandro Di Giorgio, and Davide Trotta. When Lawvere meets Peirce: an equational presentation of boolean hyperdoctrines. In *49th International Symposium on Mathematical Foundations of Computer Science*, volume 306 of *Leibniz International Proceedings in Informatics*, pages 30:1–19. Dagstuhl Publishing, 2024. DOI: 10.4230/LIPIcs.MFCS.2024.30.
- [7] Filippo Bonchi, Joshua Holland, Robin Piedeleu, Paweł Sobociński, and Fabio Zanasi. Diagrammatic algebra: from linear to concurrent systems. *Proceedings of the ACM on Programming Languages*, 3(POPL):25:1–28, 2019. DOI: 10.1145/3290338.
- [8] Filippo Bonchi, Alessio Santamaria, Jens Seeber, and Paweł Sobociński. On doctrines and cartesian bicategories. In *9th Conference on Algebra and Coalgebra in Computer Science*, volume 211 of *Leibniz International Proceedings in Informatics*, pages 10:1–17. Dagstuhl Publishing, 2021. DOI: 10.4230/LIPIcs.CALCO.2021.10.
- [9] Filippo Bonchi, Jens Seeber, and Paweł Sobociński. Graphical conjunctive queries. In *27th EACSL Annual Conference on Computer Science Logic*, volume 119 of *Leibniz International Proceedings in Informatics*, pages 13:1–23. Dagstuhl Publishing, 2018. DOI: 10.4230/LIPIcs.CSL.2018.13.
- [10] Filippo Bonchi, Jens Seeber, and Paweł Sobociński. The axiom of choice in cartesian bicategories. In *8th Conference on Algebra and Coalgebra in Computer Science*, volume 139 of *Leibniz International Proceedings in Informatics*, pages 15:1–17. Dagstuhl Publishing, 2019. DOI: 10.4230/LIPIcs.CALCO.2019.15.
- [11] Filippo Bonchi, Paweł Sobociński, and Fabio Zanasi. A categorical semantics of signal flow graphs. In *Concurrency Theory*, volume 8704 of *Lecture Notes in Computer Science*, pages 435–450. Springer, 2014. DOI: 10.1007/978-3-662-44584-6_30.
- [12] Filippo Bonchi, Paweł Sobociński, and Fabio Zanasi. Interacting bialgebras are Frobenius. In *Foundations of Software Science and Computation Structures*, volume 8412 of *Lecture Notes in Computer Science*, pages 351–365. Springer, 2014. DOI: 10.1007/978-3-642-54830-7_23.
- [13] Filippo Bonchi, Paweł Sobociński, and Fabio Zanasi. Interacting Hopf algebras. *Journal of Pure and Applied Algebra*, 221(1):144–184. DOI: 10.1016/j.jpaa.2016.06.002.
- [14] Filippo Bonchi, Paweł Sobociński, and Fabio Zanasi. Full abstraction for signal flow graphs. In *Proceedings of the 42nd Annual ACM SIGPLAN-SIGACT Symposium on Principles of Programming Languages*, volume 50(1) of *SIGPLAN Notices*, pages 515–526. Association for Computing Machinery, 2015. DOI: 10.1145/2775051.2676993.
- [15] Roberto Bruni and Fabio Gadducci. Some algebraic laws for spans (and their connections with multirelations). *Electronic Notes in Theoretical Computer Science*, 44(3):175–193, 2003. DOI: 10.1016/S1571-0661(04)80937-X.

- [16] Roberto Bruni, Ivan Lanese, and Ugo Montanari. A basic algebra of stateless connectors. *Theoretical Computer Science*, 366(1–2):98–120, 2006. DOI: 10.1016/j.tcs.2006.07.005.
- [17] Wojciech Buszkowski. Type logics and pregroups. *Studia Logica*, 87(2–3):145–169, 2007. DOI: 10.1007/s11225-007-9083-4.
- [18] Aurelio Carboni and Robert F. C. Walters. Cartesian bicategories I. *Journal of Pure and Applied Algebra*, 49(1–2):11–32, 1987. DOI: 10.1016/0022-4049(87)90121-6.
- [19] Bob Coecke and Ross Duncan. Interacting quantum observables: categorical algebra and diagrammatics. *New Journal of Physics*, 13(4):043016, 2011. DOI: 10.1088/1367-2630/13/4/043016.
- [20] Bob Coecke, Éric O. Paquette, and Dusko Pavlovic. Classical and quantum structuralism. In *Semantic Techniques in Quantum Computation*, pages 29–69. Cambridge University Press, 2009. DOI: 10.1017/CB09781139193313.003.
- [21] Bob Coecke and Aleks Kissinger. *Picturing Quantum Processes: a first course in quantum theory and diagrammatic reasoning*. Cambridge University Press, 2017. ISBN: 9781316219317.
- [22] Bob Coecke and Dusko Pavlovic. Quantum measurements without sums. In *Mathematics of Quantum Computing and Technology*, pages 567–604. Taylor and Francis, 2007. ISBN: 9780429143410.
- [23] Bob Coecke, Dusko Pavlovic, and Jamie Vicary. A new description of orthogonal bases. *Mathematical Structures in Computer Science*, 23(3):555–567, 2013. DOI: 10.1017/S0960129512000047.
- [24] Brandon Coya and Brendan Fong. Corelations are the prop for extraspecial commutative Frobenius monoids. *Theory and Applications of Categories*, 32(11):380–395, 2017.
- [25] Alessandro Di Giorgio. *Diagrammatic Algebras of Relations*. PhD thesis, Università degli Studi di Pisa, 2024.
- [26] Ivan Di Liberti, Fosco Loregian, Chad Nester, and Paweł Sobociński. Functorial semantics for partial theories. *Proceedings of the ACM on Programming Languages*, 5(POPL):57:1–28, 2021. DOI: 10.1145/3434338.
- [27] Kosta Došen and Zoran Petrić. Syntax for split preorders. *Annals of Pure and Applied Logic*, 164(4):443–481, 2013. DOI: 10.1016/j.apal.2012.10.008.
- [28] Thomas Fox. Coalgebras and cartesian categories. *Communications in Algebra*, 4(7):665–667, 1976. DOI: 10.1080/00927877608822127.
- [29] Peter J. Freyd and Andre Scedrov. *Categories, allegories*. Volume 39 of *Mathematical Library*. North-Holland, 1990. ISBN: 9780444703682.

- [30] Tobias Fritz. A synthetic approach to Markov kernels, conditional independence, and theorems on sufficient statistics. *Advances in Mathematics*, 370:107239, 2020. DOI: 10.1016/j.aim.2020.107239.
- [31] Nathan Haydon and Paweł Sobociński. Compositional diagrammatic first-order logic. In *Diagrammatic Representation and Inference*, volume 12169 of *Lecture Notes in Computer Science*, pages 402–418. Springer, 2020. DOI: 10.1007/978-3-030-54249-8_32.
- [32] Nathan Haydon. *Peirce’s existential graphs and the logic of string diagrams*. PhD thesis, Tallinn University of Technology, 2024. DOI: 10.23658/taltech.31/2024.
- [33] Martin Hyland and John Power. The category theoretic understanding of universal algebra: Lawvere theories and monads. *Electronic Notes in Theoretical Computer Science*, 172:437–458, 2007. DOI: 10.1016/j.entcs.2007.02.019.
- [34] Bjarni Jónsson and Alfred Tarski. Representation problems for relation algebras. *Bulletin of the American Mathematical Society*, 54:80–1192, Abstract #89, 1948.
- [35] Stephen Lack. Composing PROPs. *Theory and Applications of Categories*, 13(9):147–163, 2004.
- [36] Joachim Lambek. Type grammars as pregroups. *Grammars*, 4(1):21–39, 2001. DOI: 10.1023/A:1011444711686.
- [37] Joachim Lambek. *From Word to Sentence: a computational algebraic approach to grammar*. Polimetrica, 2008. ISBN: 9788876991172.
- [38] F. William Lawvere. Ordinal sums and equational doctrines. In *Seminar on Triples and Categorical Homology Theory*, volume 80 of *Lecture Notes in Mathematics*, pages 141–155. Springer, 1969. DOI: 10.1007/BFb0083085.
- [39] F. William Lawvere. Functorial semantics of algebraic theories. *Proceedings of the National Academy of Sciences of the United States of America*, 50(5):869–872, 1963. DOI: 10.1073/pnas.50.5.869.
- [40] Saunders Mac Lane. Categorical algebra. *Bulletin of the American Mathematical Society*, 71(1):40–106, 1965. DOI: 10.1090/S0002-9904-1965-11234-4.
- [41] Chad Nester. *Partial and Relational Algebraic Theories*. PhD thesis, Tallinn University of Technology, 2024. DOI: 10.23658/taltech.4/2024.
- [42] Dusko Pavlovic. Maps II: chasing diagrams in categorical proof theory. *Logic Journal of the IGPL*, 4(2):159–194, 1996. DOI: 10.1093/jigpal/4.2.159.
- [43] Dusko Pavlovic. Quantum and classical structures in nondeterministic computation. In *Quantum Interaction*, volume 5494 of *Lecture Notes in Computer Science*, pages 143–158. Springer, 2009. DOI: 10.1007/978-3-642-00834-4.

-
- [44] Dusko Pavlovic. Geometry of abstraction in quantum computation. *Proceedings of Symposia in Applied Mathematics*, 71:233–267, 2012. DOI: 10.1090/psapm/071.
- [45] Dusko Pavlovic. Monoidal computer I: basic computability by string diagrams. *Information and Computation*, 226:94–116, 2013. DOI: 10.1016/j.ic.2013.03.007.
- [46] Dusko Pavlovic. Lambek pregroups are Frobenius spiders in preorders. *Compositionality*, 4(1):1–21, 2022. DOI: 10.32408/compositionality-4-1.
- [47] Dusko Pavlovic. *Programs as Diagrams: from categorical computability to computable categories*. Volume of *Theory and Applications of Computability*. Springer, 2023. ISBN: 9783031348266.
- [48] Robin Piedeleu. The algebra of parity games. Preprint, 2025. DOI: 10.48550/arXiv.2501.18499.
- [49] Robin Piedeleu and Fabio Zanasi. A finite axiomatisation of finite-state automata using string diagrams. *Logical Methods in Computer Science*, 19(1):13:1–38, 2023. DOI: 10.46298/lmcs-19(1:13)2023.
- [50] Anne Preller. Toward discourse representation via pregroup grammars. *Journal of Logic, Language and Information*, 16:173–194, 2007. DOI: 10.1007/s10849-006-9033-y.
- [51] Jens Seeber. *Logical completeness for string diagrams*. PhD thesis, Scuola IMT Alti Studi Lucca, 2020. DOI: 10.6092/imtlucca/e-theses/317.
- [52] Peter Selinger. A survey of graphical languages for monoidal categories. In *New Structures for Physics*, volume 813 of *Lecture Notes in Physics*, pages 289–355. Springer, 2010. DOI: 10.1007/978-3-642-12821-9_4.
- [53] Paweł Sobociński. Nets, relations and linking diagrams. In *Algebra and Coalgebra in Computer Science*, volume 8089 of *Lecture Notes in Computer Science*, pages 282–298. Springer, 2013. DOI: 10.1007/978-3-642-40206-7_21.
- [54] Fabio Zanasi. The algebra of partial equivalence relations. *Electronic Notes in Theoretical Computer Science*, 325:313–333, 2016. DOI: 10.1016/j.entcs.2016.09.046.